

Electronic Total Station

R-300 SERIES

R-315(N)/R-325(N)/R-335(N)/R-322(N)/R-323(N)/R326

Special Functions

PTL Software Ver.346

PENTAX Industrial Instruments Co., Ltd.

Copyright

Copyright © 2002 PENTAX Industrial Instruments Co., Ltd.

All Rights Reserved

PENTAX Industrial Instruments Co., Ltd. is a sole proprietor of the PowerTopoLite software. The PowerTopoLite software and publication or parts thereof, may not be reproduced in any form, by any method, for any purpose.

PENTAX Industrial Instruments Co., Ltd. makes no warranty, expressed or implied, including but not limited to any implied warranties or merchantability or fitness for a particular purpose, regarding these materials and makes such materials available.

Document Ver.1.03: July. 2004

Display and Keyboard

- Basic display and keyboard of **R-300 series** are described below, and the function keys of PowerTopoLite are described at "[2. ACCESSING THE POWERTOPOLITE](#)".
- The description concerning only Reflectorless type, R-315N/R-325N/R-335N/R-322N/R-323N, is put in ().

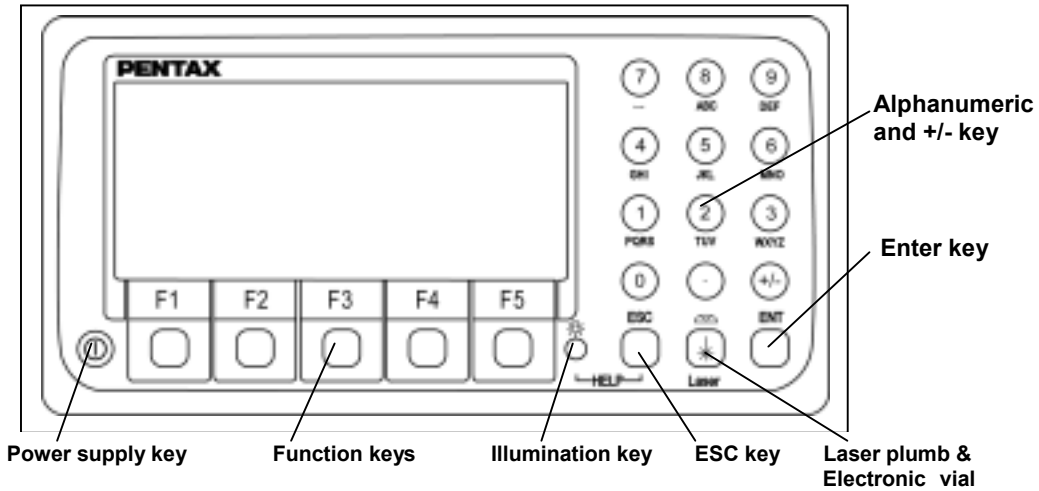

Operation Key

Key	Description
[POWER]	ON/OFF of power supply
[ESC]	Returns to previous screen or cancels an operation.
[Illumination]	Turns the illumination of the LCD display and telescope reticle on and off.
[ENT]	Accepts the selected, highlighted, choice or the displayed screen value.
[Laser]	Displays the laser plummet *1, Electronic vial function, and the LD point screen when you push the laser plummet/electronic vial key. (Refer to "2.5 LD point function", "3.2 Laser plummet", and "3.5 Leveling with electronic vial" of "Instruction Manual"). *1: Only the product with the laser plummet function
[Alphanumeric]	At the numerical value screen, the numerical value and the sign '.' displayed are input. The English characters printed right under numeric of each key are input.
[HELP]	Pressing [ILLU]+[ESC] causes a help menu to appear in A MODE or B MODE or causes a help messages to appear.

Function key

Display	F. Key	Description
Mode A		
[MEAS]	F1	Pressing this key one time measures the distance in normal mode(another measurement type can be selected by Initial Setting 2.)
[MEAS]	F1	Pressing this key twice measures the distance in coarse mode(another measurement type can be selected by Initial Setting 2.)
[TARGET]	F2	Select the target type by following order. SHEET / PRISM / REFLECTORLESS (Reflectorless type instrument) SHEET/ PRISM (Prism type instrument)
[0 SET]	F3	Resets the horizontal angle to 0° 0' 0" by pressing twice.
[DISP]	F4	Switches the display composition in the order "H.angle / H.dst. / V.dst.", "H.angle / V.angle / S.dst." and "H.angle / V.angle / H.dst. / S.dst. / V.dst.".
[MODE]	F5	Switches the screen between MODE A and MODE B.
Mode B		
[S.FUNC]	F1	PowerTopoLite Special Functions
[ANG SET]	F2	Brings up the angle setting screen for setting angle-related parameters (H.ANGLE/%GRADE, H.ANGLE INPUT and R/L REVERSE).
[HOLD]	F3	Pressing this key twice retains (holds) the horizontal angle shown on the display.
[CORR]	F4	Brings up the screen for changing the Target constant, Temperature, Pressure setting.
[MODE]	F5	Toggles the screen between MODE A and MODE B.
Other functions		
[←]	F1	Moves the cursor to the left.
[→]	F2	Moves the cursor to the right.
[▲]	F1	Goes back five items on the screen
[▼]	F2	Goes forward five items on the screen.
[↑]	F3	Moves the cursor up
[↓]	F4	Moves the cursor down
RETICLE	F3	Changing the Reticle illumination when pressing Illumination key
LCD	F4	Changing the LCD contrast when pressing Illumination key
ILLU	F5	Changing the LCD illumination when pressing Illumination key
[CLEAR]	F5	Clear the figure
[SELECT]	F5	Open the selection window

- The Function keys of each PowerTopoLite function are described at "[ACCESSING THE POWERTOPOLITE](#)" and at the each function.

Display combination of Mode A or Mode B

Function	MODE A	MODE B
F1	MEAS	S.FUNC
F2	TARGET	ANG SET
F3	0 SET	HOLD
F4	DISP	CORR
F5	MODE	MODE

- Mode A or Mode B is switched by pressing [F5] [MODE].

Alphanumeric Input

The point name etc. is input by the alphanumeric keys as following.

Key	Letter under Key	Letter & Figure order to input
[0]		[@][.][_][-][:][/][0]
[1]	PQRS	[P][Q][R][S][p][q][r][s][1]
[2]	TUV	[T][U][V][t][u][v][2]
[3]	WXYZ	[W][X][Y][Z][w][x][y][z][3]
[4]	GHI	[G][H][I][g][h][i][4]
[5]	JKL	[J][K][L][j][k][l][5]
[6]	MNO	[M][N][O][m][n][o][6]
[7]		[][?][!][_][][^][][&][7]
[8]	ABC	[A][B][C][a][b][c][8]
[9]	DEF	[D][E][F][d][e][f][9]
[.]		[.][,][:][;][#][(][)]
[+/-]		[+][-][*][/][%][=][<][>]

CONTENTS

Copyright

Display and Keyboard

Memories in the Instrument

Relations between memories and each function

(TOP COVER)

Display and Keyboard	2
Operation Key	2
Function key	3
Display combination of Mode A or Mode B	3
Alphanumeric Input	4
1. INTRODUCTION	7
1.1 Introduction	7
1.2 Before using the PowerTopoLite manual	7
2. ACCESSING THE POWERTOPOLITE	9
2.1 How to access the PowerTopoLite	9
2.2 Allocation of each PowerTopoLite Function key	10
2.3 Typical Function keys of the PowerTopoLite	11
3. FILE MANAGER	12
3.1 Information of the remaining memory available	12
3.2 Creation of a new Job	12
3.3 Selection of a Job name	13
3.3.1 Selection of a Job	13
3.3.2 Selection by a Job name input	13
3.4 Deletion of a Job name	14
3.4.1 Deletion from a Job list	14
3.4.2 Deletion from a Job name search	15
4. MEASURE	16
4.1 Station setup [By Rectangular Coordinates]	17
4.1.1 Point name, PN, input	17
4.1.2 Coordinates, X, Y, Z, IH, and PC input	17
4.2 Station Orientation	21
4.2.1 Station orientation	21
4.3 Measuring	22
4.4 Point Code	23
4.5 Remote, Offset, Station, H. angle function	25
4.5.1 Remote	25
4.5.2 Offset	26
4.5.3 Station	28
4.5.4 H. angle	28
4.6 Station setup [By Polar Coordinates]	29
4.6.1 Point name, PN, input	29
4.6.2 IH, TEMP, PRESS, ppm and PC input	29
4.8 Measuring	32
4.9 Offset	34
5. VIEW AND EDIT	35
5.1 Graphical View	35
5.2 Create the Rectangular Point	36
5.3 Edit the Data	37
6. FREE STATIONING	38
6.1 Stationing by more than 3known points	38

6.2	Stationing by two known points	41
7.	STAKE OUT	39
7.1	STAKE OUT	39
7.2	POINT TO LINE	46
8.	CALCULATIONS	49
8.1	COGO	49
8.1.1	INVERSE	49
8.1.2	POINTS COORDINATES	49
8.1.2.1	Point Coordinates, Distance and H. angle	49
8.1.2.2	Distance and H. angle	56
8.1.2.3	H. angle input	57
8.1.3	CIRCLE RADIUS	58
8.1.4	LINE-ARC INTERSECTION	60
8.1.5	LINE-LINE INTERSECTION	59
8.1.6	ARC-ARC INTERSECTION	66
8.1.7	DISTANCE OFFSET	69
8.1.8	POINT DISTANCE OFFSET	71
8.1.9	ARC DISTANCE OFFSET	74
8.2	2D SURFACE	77
8.3	3D SURFACE AND VOLUME	80
8.4	REM	82
9	VPM	83
10	RDM	877
10.1	PH input	877
10.2	Reference point - Target distance	877
10.3	Target- Target distance	888
10.4	New Reference point selection	888
11.	TRAVERSE	9090
11.1	Start point measuring	9191
11.2	Corner point measuring	94
11.3	Calculation	9595
12.	INPUT / OUTPUT	9898
12.1	Input from the PC	9898
12.2	Output to the PC	9999
12.3	Communication setup	100100
12.3.1	Receiving data setting	100100
12.3.2	Sending data setting	101101
12.4	About DataLink DL- 01 Software	103103
13.	PREFERENCE	106106
13.1	Language selection	106106
13.2	Coordinate axis definition	107107
13.3	Input method selection	109109
13.4	Action method selection	111111
13.5	Remote method selection	112112
13.6	Compare method selection	113113
13.7	Request aiming selection	114115
13.8	EDM settings selection	115115
13.9	Elevation Factor	116116

1. INTRODUCTION

1.1 Introduction

Thank you for your first looks at PowerTopoLite by reading this manual. The PowerTopoLite is a user friendly data collection and calculation program for the PENTAX total station **R-300** series.

PowerTopoLite is developed based on PowerTopo, which is known as versatile on-board software for PENTAX ATS total station series. The optimum combination of PowerTopo and **R-300** hardware makes PowerTopoLite as an easy and useful fieldwork tool.

The icon based main menu offers you the following possibilities.

- FILE MANAGER
- MEASURE
- VIEW AND EDIT
- FREE STATIONING
- STAKE OUT
- CALCULATIONS
- VPM
- RDM
- TRAVERSE
- TRANSFER
- PREFERENCE

1.2 Before using the PowerTopoLite manual

- Memories in the instrument

The **R-300** series instrument incorporates not only the PowerTopoLite surveying programs as the Special function but also File manager and Data transfer programs.

The internal memory in the instrument can store the maximum 7500 point's data.

- Relations between the Memory and each Function

Function	Read from the stored data	Write to the stored data
Measure	SP, BSP	SP, BSP, FP (SD)
Stake Out	SP, BSP, SOP	SP, BSP, SOP, OP
Point to Line	SP, BSP, KP1, KP2	SP, BSP, KP1, KP2, OP
Free Stationing	Each KP	Each KP, SP (CD)
Traverse	SP, BSP	SP, FP (SD)
VPM	SP, BSP, Each KP	SP, BSP, Each KP, CP (CD)

Station point:	SP	Foresight point:	FP	Backsight point:	BSP	Stakeout point:	SOP
Known point :	KP	End point :	EP	Observation point:	OP		
Conversion point:	CP	Crossing point:	CRP	Surveyed data:	SD	Conversion data:	CD

- IH and PH

IH stands for "Instrument Height" and PH stands for "Prizm Height".

- The PowerTopoLite manual mainly describes the **R-300** special functions, and the basic operations are described in the (basic) **R-300** manual. And, therefore, refer to the **R-300** basic manual regarding the **R-300** general instrument operations.

The PowerTopoLite screens vary with the selections of the "[Preference](#)". The factory default settings of the Preference are shown there. It is also possible to select "Process type" that took over functionality of "PowerTopoLite" or "Structure type" that took over functionality of "PCS-300" in "[Action Method Selection](#)".

- The **R-300** series instrument has a Job name of "PENTAX" as its default setting. And, therefore, each data is stored in the "PENTAX" unless another new Job name is created. When another Job name is created, each data is stored in the new Job name.
- The input range of the X, Y and Z Coordinate is "00000000.000" – "99999999.998".
- The input range of the Instrument and Prism height is "0000.000" – "9999.998".
- The PC, PointCodeList, is added to the PN, Coordinates X, Y, Z and IH (PH or HI) and you can input your desired attributes for the point. If you have PointCodeList in the job named "PointCodeList", you can easily select one of the PointCode from the list or edit one of them after pressing [ENT]. Please, note that Point Code, which is saved in the other job can not be referred as a list.
- There are two Coordinates types of Rectangular and Polar. The VO, TO offset and the remote measurement are possible when you select the Rectangular Coordinates.
- When you measure in EDM SETTINGS of COARSE TRACKING, the **R-300** displays a distance value to two decimal places. However, distance data of polar coordinates are displayed by EDIT function to three decimal places even, and sent to four decimal place. So, " 0 " or " 00 " is added to the distance data after the third decimal point in COARSE TRACKING mode.
For example

Displayed value:	123.45
Displayed by EDIT:	123.450
Sent polar data:	123.4500
- Rectangular coordinates is displayed, stored, and sent to three decimal place even if in COARSE TRACKING or FINE MEASURE mode.
- You can change the distance measurement mode during measuring operation by pressing the EDM key at the MEASURE and VPM functions.
- The same Point Name of the plural polar points can be saved.

2. ACCESSING POWERTOPOLITE

2.1 How to access PowerTopoLite

To access the **R-300** Special Functions of the PowerTopoLite, perform the following procedures.

a. Press the Power (ON/OFF) key to view the **R-300** start-up screen.

b. It turns to ELECTRONIC VIAL screen after a while.

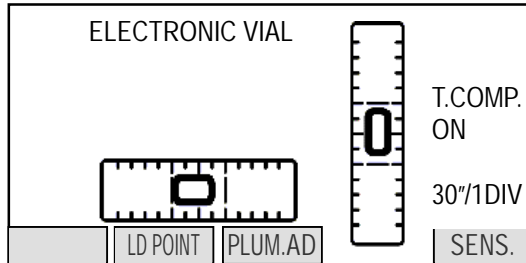

c. Press the [ESC], [Laser] or [ENT] to view Mode A screen.

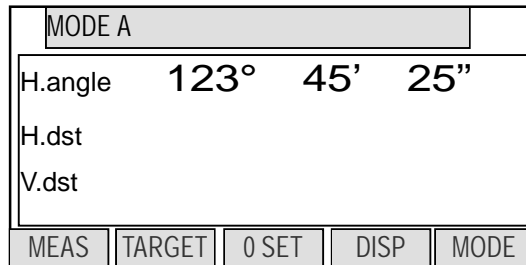

d. Press the [F5][MODE] to view Mode B screen.

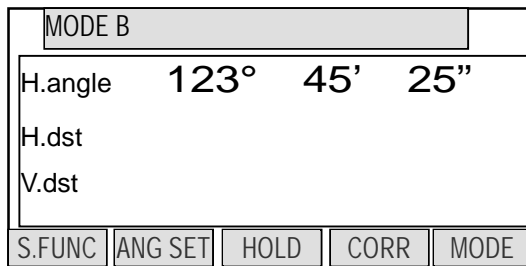

e. Press [F1][S.FUNC] to view Functions of PowerTopoLite screen

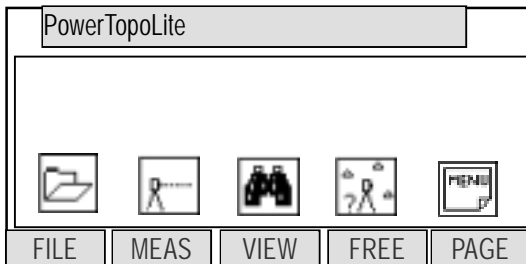

f. Press [F5][PAGE] to view another Function combination of PowerTopoLite screen.

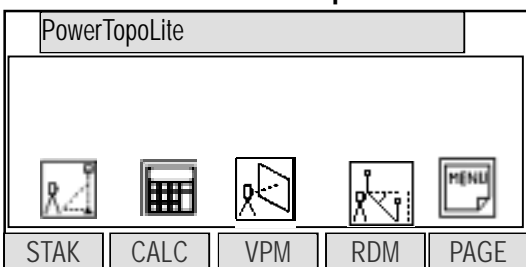

e. Press **[F1][S.FUNC]** to view Functions of PowerTopoLite screen

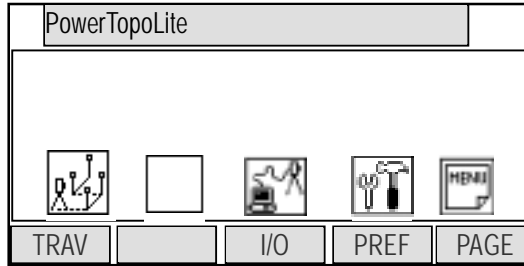

2.2 Allocation of each PowerTopoLite Function key

a. FILE, MEAS, VIEW, FREE, STAK, CALC, I/O and **PREF** functions

Function key		Description
F1	FILE	File manager
F2	MEAS	Measure
F3	VIEW	View and Edit
F4	FREE	Free Stationing

Other four Functions are viewed by pressing **[F5][PAGE]**.

Function key		Description
F1	STAK	Stake out
F2	CALC	Calculation
F3	VPM	Virtual Plane Measurement
F4	RDM	Remote Distance Measurement

Other four Functions are viewed by pressing **[F5][PAGE]**.

Function key		Description
F1	TRAV	Stake out
F2		N/A
F3	I/O	Input and Output
F4	PREF	Preference

b. INVERSE, POINT COORDINATES, LINE-LINE INTERSECTION functions

CALCULATION screen is viewed by pressing **[F2][CALC]**.

The CALCULATION consists of COGO, 2D SURFACE and 3D SURFACE & VOLUME functions.

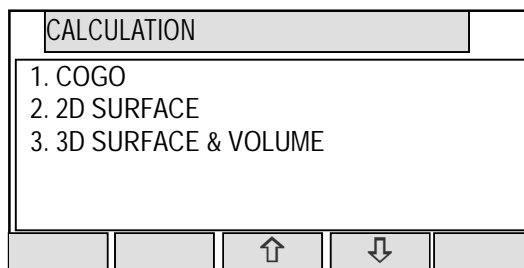

COGO screen is viewed by selecting 1. COGO and pressing the **[ENT]**.

The COGO consists of INVERSE, POINT COORDINATE, CIRCLE RADIUS LINE-ARC INTERSECTION, LINE-LINE INTERSECTION, ARC-ARC INTERSECTION, DISTANCE OFFSET, POINT DISTANCE OFFSET, POINT DISTANCE OFFSET, ARC DISTANCE OFFSET, and functions.

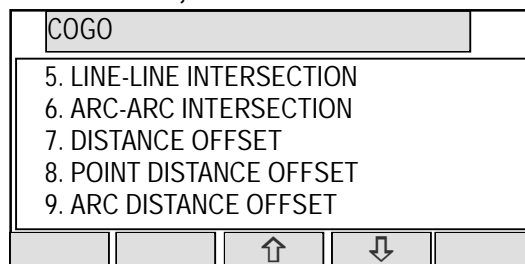
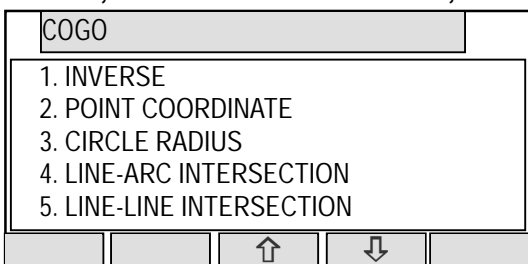

2.3 Typical Function keys of PowerTopoLite

Following function keys are typical ones of PowerTopoLite and each function key is described for each function of this Manual.

Function key	Description
ENTER	Opens the input screen of Coordinate values etc.
PAGE	Views another function combination.
SELECT	Selects the Character and moves to next input at PN input etc.
ACCEPT	Enters the displayed values without new Coordinates value input etc.
INPUT	Inputs your desired Horizontal angle.
BSP	Views the BSP SETUP screen to input its Coordinates.
SAVE	Saves inputted data.
ME/SAVE	Measures and then saves inputted data.
EDIT	Changes the Point name or Prism height.
REMOTE	Views your aiming point Coordinates.
OFFSET	Views the Target Coordinates adding the offset values.
STATION	Returns to the STATION POINT SETUP screen.
H. ANGLE	Returns to the STATION POINT H.ANGLE SETUP screen.
LIST	Views the POINT SELECTION FROM THE LIST screen.
ZOOM ALL	Returns to original size.
ZOOM IN	Magnifies the graphics size.
ZOOM OUT	Reduces the graphics size.
DISP	Views point or point & graphic or point & point name or all.
DELETE	Views the POINT DELETION screen.
FIND PN	Views the PN search screen by inputting the Point name.
ADD	Allow you to add more points for the free stationing.
CALC	Starts the calculation of the free stationing.
NEXT	Views the next known point Coordinates setup screen.
DATA	Views the TARGET POINT screen.
TARGET	Selects the Target type
EDM	Selects the EDM settings
ALL	Selects all points of current job
ORDER	The order of selected points



3. FILE MANAGER

The Data storage memory status, creating a new Job name and the Selection and Deletion of a Job name are executed by this function.

From the PowerTopoLite screen, press [F1][FILE] to view the FILE MANAGEMENT screen.

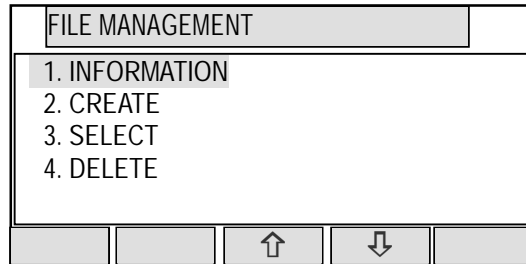

3.1 Information of the remaining memory available

Press [ENT] to view INFORMATION screen.

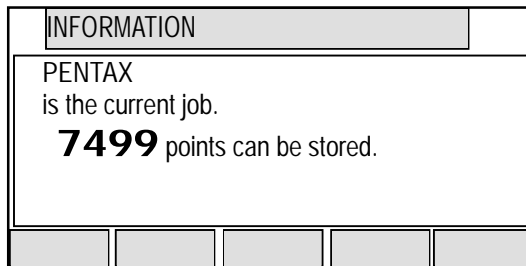

The remaining memory available and a JOB name PENTAX are viewed on the screen. The Job name "PENTAX" is a default setting.

3.2 Creation of a new Job

Select 2. CREATE by down arrow key.

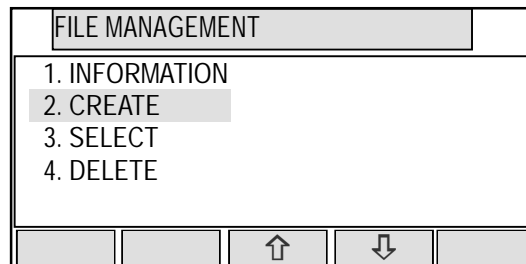

Press [ENT] to view the JOB NAME INPUT screen.

- The Job name input method can be selected by the "[Input method selection](#)" of the "Preference". This is the "10 KEY SYSTEM" input selection.

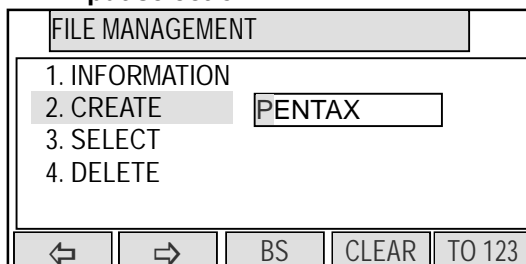

- If a new Job is created, the new data are stored in this new Job.

3.3 Selection of a Job name

Select 3. SELECT by pressing the down arrow key.

FILE MANAGEMENT				
1. INFORMATION				
2. CREATE				
3. SELECT				
4. DELETE				
		↑	↓	

Press [ENT] to view JOB SELECTION screen.

JOB SELECTION				
1. JOB LIST SEARCH				
2. JOB NAME SEARCH				
		↑	↓	

3.3.1 Selection of a Job

Select 1. JOB LIST SEARCH and press [ENT] to view its screen.

JOB LIST is a list of all stored Jobs.

JOB LIST SEARCH				
1. PENTAX				
2. NERIMA				
3. TOKYO				
▲	▼	↑	↓	

Select your desired Job name and press [ENT] to select.

3.3.2 Selection by a Job name input

Select 2. JOB NAME SEARCH by pressing the down arrow key.

- The JOB NAME SEARCH is the search by inputting your desired job name.

JOB SELECTION				
1. JOB LIST SEARCH				
2. JOB NAME SEARCH				
		↑	↓	

Press [ENT] to view the JOB NAME INPUT screen.

JOB NAME INPUT				
TOKYO				
←	→	BS	CLEAR	TO 123

Input your desired JOB NAME and press [ENT] to view the JOB LIST SEARCH screen.

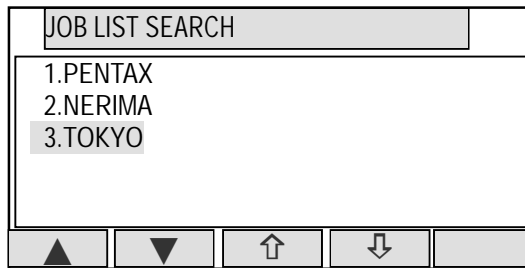

Press [ENT] to select this.

3.4 Deletion of a Job name

Select 4. DELETE by pressing the down arrow key.

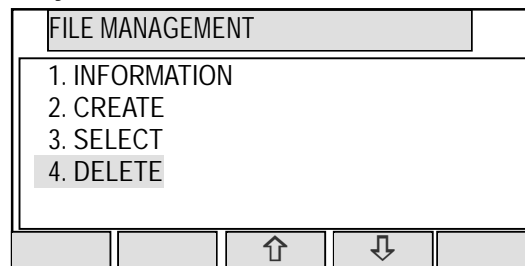

Press [ENT] to view JOB DELETION screen.

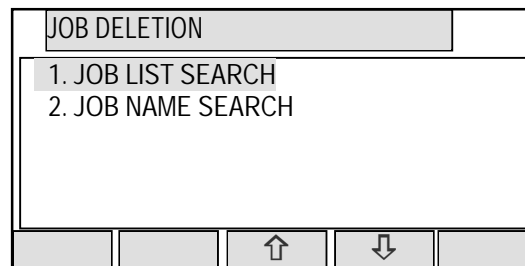

3.4.1 Deletion from a Job list

Select 1. JOB LIST SEARCH and Press [ENT] to view its screen.

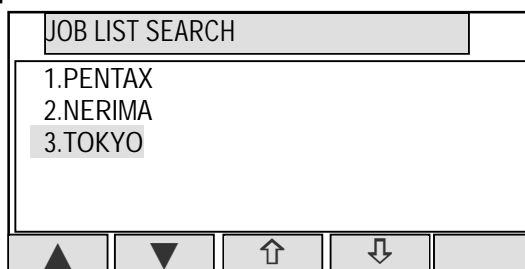

If TOKYO is selected, deletion confirmation screen is viewed.

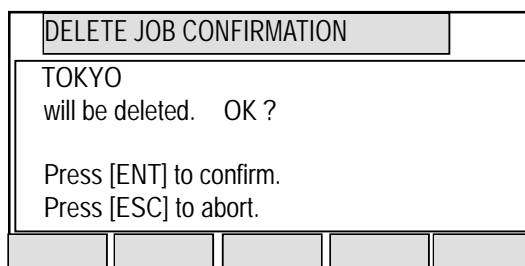

Press [ENT] to delete or [ESC] to abort.

3.4.2 Deletion from a Job name search

Select 2. JOB NAME SEARCH by pressing the down arrow key.

JOB DELETION				
1. JOB LIST SEARCH				
2. JOB NAME SEARCH				
		↑	↓	

Press [ENT] to view the JOB NAME INPUT screen.

JOB NAME INPUT				
1. JOB LIST SEARCH				
2. JOB NAME SEARCH TOKYO				
←	→	BS	CLEAR	TO 123

Input your desired JOB NAME to delete and press [ENT] to view the DELETE JOB CONFIRMATION screen.

DELETE JOB CONFIRMATION				
TOKYO				
will be deleted. OK ?				
Press [ENT] to confirm.				
Press [ESC] to abort.				

Press [ENT] to delete or [ESC] to abort.

The **R-300** series instrument has a Job name of the “PENTAX” as its default setting. Therefore, each data is stored in “PENTAX” unless another new Job name is created. When another Job name is created, each data is stored in the new Job name.

4.1 Station setup [By Rectangular Coordinates]

Press [F2][MEAS] of the PowerTopoLite screen to view the MEASURE METHOD SELECTION screen.

MEASURE METHOD SELECTION

1. RECTANGULAR COORD.
2. POLAR COORD.

↑ ↓

Select 1. RECTANGULAR COORD. and press [ENT] to view the STATION POINT SETUP screen.

STATION POINT SETUP

1. PN:
2. X: + 00000000.000 m
3. Y: + 00000000.000 m
4. Z: + 00000000.000 m
5. IH: 0000.000 m

SAVE LIST ↑ ↓ ACCEPT

The ↑/↓ mark is used to scroll up / down. 6. PC is viewed by scrolling down.

STATION POINT SETUP

2. X: + 00000000.000 m
3. Y: + 00000000.000 m
4. Z: + 00000000.000 m
5. IH: 0000.000 m
6. PC:

SAVE LIST ↑ ↓ ACCEPT

4.1.1 Point name, PN, input

Press [ENT] to view the PN screen.

The [ENT] is used for both accepting the selected choice and opening the input screen of the Coordinates values etc..

PN

1. PN:
2. X: + 00000000.000 m
3. Y: + 00000000.000 m
4. Z: + 00000000.000 m
5. IH: 0000.000 m

← → BS CLEAR TO 123

Input your desired point name by pressing keys, and after all Characters are input, press [ENT]. Four character selection methods are available. (Refer to the [“13.3 Input method selection”](#))

4.1.2 Coordinates, X, Y, Z, IH, and PC input

It goes 2. X coordinate automatically.

X

1. PN: POT1
2. X: + 00000000.000 m
3. Y: + 00000000.000 m
4. Z: + 00000000.000 m
5. IH: 0000.000 m

SAVE LIST ↑ ↓ ACCEPT

Press [ENT] to view the X coordinate input screen.
 Input X, Y and Z coordinates, Instrument height and PC as follows.
 Input your desired X coordinate value by pressing each keys.

Y coordinate:

Press [ENT] to view the Y coordinate input screen. Input your desired Y coordinate value by pressing keys.

Z coordinate:

Press [ENT] to view the Z coordinate input screen. Input your desired Z coordinate value by pressing each keys.

IH value:

Press [ENT] to view the IH, Instrument height, screen. Input your desired IH value by pressing each keys.

PC, Point Code:

Press [ENT] to view and input the PC, Point code, screen.

If PointCode exists, you can easily select them from the list. Then after pressing [ENT], you can edit Point Code data. For using Point Code List, please refer to [“4.4. Point Code”](#).

After pressing [ENT], you can edit Point Code data.

PC				
2. X: + 00000100.000m				
3. Y: - 00000200.000m				
4. Z: + 00000010.000m				
5. IH: 0010.000m				
6. PC: TEST POI				
←	→	BS	CLEAR	TO 123

Input your desired PC name by pressing keys, and press [ENT] to view next screen.

If "PROCESS TYPE" is selected in "Action method selection", after input/confirm PC data the inputted POT1 data will automatically be stored in the memory. Then the panel "STATION POINT H.ANGLE SETUP" will be displayed.

But, if "STRUCTURE TYPE" is selected in "Action method selection", it is necessary to press [ACCEPT] to proceed next panel.

● [LIST] key

All stored points can be displayed, deleted and searched as follows by pressing [F2][LIST]. Press the [F2][LIST] to view POINT SELECTION FROM THE LIST screen.

POINT SELECTION FROM THE LIST				
↑				
1 / 15				
PNx POT1				
X x + 00000100.000 m				
Y x - 00000200.000 m				
Z x + 00000010.000 m				
DELETE	FIND PN	↑	↓	

Press [F1][DELETE] to view POINT DELETION screen.

Press [F2][FIND PN] to view PN screen.

POINT DELETION				
POT1				
Do you really want to delete it ?				
Press [ENT] to confirm.				
Press [ESC] to abort.				

PN				
1. PN*:				
2. X: + 00000000.000 m				
3. Y: + 00000000.000 m				
4. Z: + 00000000.000 m				
←	→	BS	CLEAR	TO 123

[ENT] to view POINT SELECTION FROM the LIST screen.

POINT SELECTION FROM THE LIST				
↑				
2 / 15				
PNx POT2				
X x + 00000300.000 m				
Y x - 00000600.000 m				
Z x + 00000010.000 m				
DELETE	FIND PN	↑	↓	

Press [ENT] to view STATION POINT SETUP screen.

STATION POINT SETUP				
1. PN:POT2				
2. X: + 00000300.000 m				
3. Y: - 00000600.000 m				
4. Z: + 00000010.000 m				
5. IH: 0001.200 m				
SAVE	LIST	↑	↓	ACCEPT

4.2 Station Orientation

Press the [F1][ACCEPT] to view the STATION POINT H. ANGLE SETUP screen.

Please, note that the rotation of the “H.angle” depend on the rotation setting of “[Coordinate axis definition](#)”.

STATION POINT H. ANGLE SETUP				
H. angle		XXX° XX' XX"		
INPUT	0 SET	HOLD	BSP	

4.2.1 Station orientation

Input the H. angle by pressing [F2][INPUT], [F3][0SET] and [F4] [HOLD] or Reference point Coordinates by pressing [F5][BSP].

Pressing [F2][INPUT]

H ANGLE				
H. angle		XXX° XX' XX"		
←	→			CLEAR

Pressing [F5][BSP]

BSP SETUP				
1. PN:				
2. X: + 00000100.000 m				
3. Y: + 00000310.000 m				
4. Z: + 00000110.000 m				
5.PC				
SAVE	LIST	↑	↓	ACCET

Press [ENT] to view the input window.

Press [ENT] after entering the Horizontal angle. The AIM AT THE REFERENCE POINT screen is viewed when “1. ON” of “7.REQUEST AIMING” of “[Preference](#)” is selected and not viewed when “2. OFF” is selected.

In case of that BSP Coordinates are inputted, this message is always viewed on the screen.

AIM AT THE REFERENCE POINT.				
Aim at the reference point Press [ENT] when ready.				
ESC				ENT

Coordinates display and Angle & Distance display

Press the [ENT] at the STATION POINT H. ANGLE SETUP screen to view the MEASURE screen.

STATION POINT H. ANGLE SETUP				
H. angle		xxx° xx' xx"		
INPUT	0 SET	HOLD	BPS	

MEASURE				
PN				
PH		X.XXX m		
X				
Y				
Z				
MEAS	SAVE	ME/SAVE	EDIT	PAGE

Press the [MEAS] to measure the Distance and display the Coordinates.

- 1) Press [F5][PAGE] twice to view [F3][ANG & DIST].
- 2) Press [F3][ANG & DIST] to view [F3][COORD.] and Angle and Distance values.
- 3) Press [F3][COORD.] to view [F3][ANG&DIST] and Coordinates.

MEASURE				
PN				
PH		X.XXX m		
X		+ X.XXX m		
Y		+ X.XXX m		
Z		+ X.XXX m		
EDM	TARGET	ANG&DIST		PAGE



ANG. & DIST.				
PN				
PH		X.XXX m		
H.angle		XXX° XX' XX"		
V.angle		YY° YY' YY"		
H.dst		X.XXX m		
		COORD	DISP	

4.3 Measuring

Aim at the reference point and press [ENT] to view the MEASURE screen.
Then, aim at the Target point and press the [F1][MEAS] to measure it.

MEASURE	
PN	POT3
PH	1.200 m
X	+ 373.205
Y	- 73.205
Z	+ 71.149

MEAS	SAVE	ME/SAVE	EDIT	PAGE
------	------	---------	------	------

Press [F3][ME/SAVE] to measure and save the measured data.

Press [F2][SAVE] to save the measured data.

Press [F4][EDIT] to edit the PN, Point Name, PH, Prism Height and PC, Point Code.

Input your desired Point name, Prism height and Point code.

Press [F5][ACCEPT] if the current PN, PH and PC are acceptable.

If PointCode exists, you can easily select them from the list or edit one of them after pressing the [ENT]. For using Point Code List, please refer to ["4.4. Point Code"](#).

MEASURE	
1. PN:	POT5
2. PH:	000.000 m
3. PC:	XXXX

		↑	↓	ACCP
--	--	---	---	------

4.4 Point Code

The PC, PointCodeList can be used for adding your desired attributes to Rect. and Polar data. If point codes are stored under the job named "PointCodeList", you can easily select one of the PointCode from the list or edit one of them after pressing [ENT]. Please, note that Point Code, which is saved in the other job can not be referred as a list.

"PointCodeList" can be created by either using "[5.2 Create the Rectangular Point](#)" function or Importing "PointCodeList" file.

Making "PointCodeList":

Create / select "PointCodeList" job using "3. FILE MANAGER". Then input point data according to "[5.2 Create the Rectangular Point](#)". Input any value into "PN" field and leave the X, Y, and Z field "0". And input PointCode data into "PC" field.

Importing "PointCodeList" file:

PointCodeList can be used after importing it from external devices (ex. PC). After importing, it is stored in the internal memory of the instrument. To store user defined "PointCodeList", please carry out following procedure.

Preparing "PointCodeList" file:

Make a "PointCodeList.csv" file with reference to a sample "PointCodeList.csv" file that is contained in the "R-300 Supplement Disk" for the format.

Please, note that the newly entered PointCode on the instrument is not added to the PointCodeList that is stored in the memory. In this case, edit "PointCodeList.csv" separately.

Contents of "PointCodeList.csv":

```
1,,PointCodeList,
31,,1,ABC,,,,
31,,2,DEF,,,,
31,,3,GHI,,,,
31,,4,JKL,,,,
31,,5,MNO,,,,
31,,6,PQR,,,,
31,,7,STU,,,,
31,,8,VW,,,,
31,,9,XYZ,,,,
```

Format of the "PointCodeList" file

	Field 1	Field 2	Field 3	Field 4	Field 5	Field 6	Field 7
Description	Record Type	No.	Name	Description			
Ex. Line 1	1,	,	PointCodeList,	,			
	Job record	Job No.: (N/A)	Job Name (Fixed for "PointCodeList".)				
Ex. Line 2	31,	,	2,	DEF,	,	,	,
	Coord. data record	Point No.: (N/A)	Point Name (Shoul not duplicated and Max. 15 Character.)	Point Code (Max. 15 Character.)			

Setting the PROTOCOL:

Press the [F3][I/O] of the PowerTopoLite screen to view the TRANSFER screen.

To check the communication setting, select the "4. COMMUNICATION SETUP" in the "TRANSFER" screen and press [ENT] to view "COMM. SETTING SELECTION" screen.

Then select "1. RECEIVE RECT.DATA" and set

"1. BAUD RATE" to "1200",

"6. XON/XOFF" to "OFF" for using "DL-01",
"ON" for using "HYPER TERMINAL".

"7. PROTOCOL" to "OFF"

"8. RECORD DELIMITER" to "CR+LF"
and press [ACCEPT].

(cf. "[12.3.1 Receiving data setting](#)")

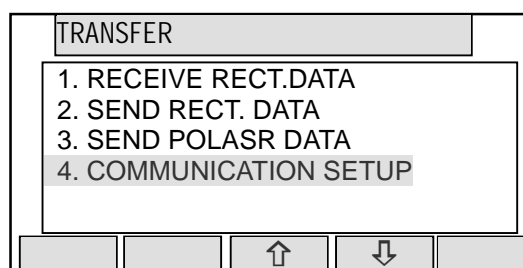

Receive rect. Data:

After setting the parameters, select the "1. RECEIVE RECT. DATA" in the "TRANSFER" screen and press [ENT] to view "FORMAT SELECTION" screen. In this screen select "3.ExtCSV" to send PointCodeList.(cf. "[1 Input from the PC](#)")

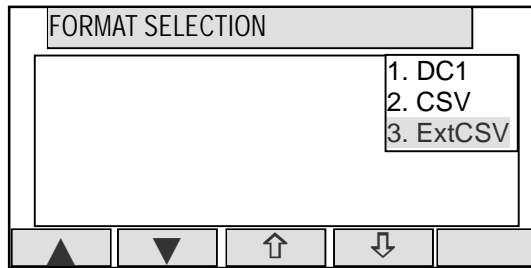

After complete data transfer, number of received points is displayed. Press [ENT].

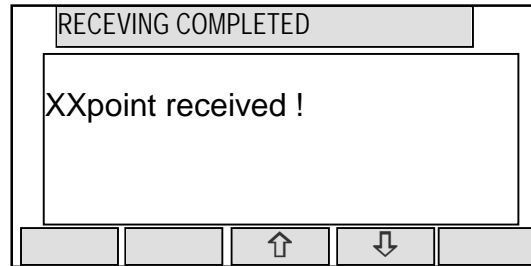

If the name of job in the PointCodeList file (ex. "1,,PointCodeList,") is same as current job and you want to overwrite or append, select "1. OVERWRITE" or "2. APPEND".

If the name of job in the PointCodeList file (ex. "1, PointCodeList,") is different from current job or if you don't want overwrite or append when jobs names are same, select "3. SAVE".

Received data will be written into the internal memory of the instrument.

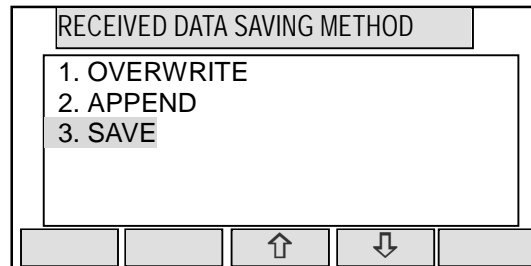

4.5 Remote, Offset, Station, and H. angle function

4.5.1 Remote

Press [F5][PAGE] to view another MEASURE menu.

Press [F1][REMOTE] once and then quickly press this key again to measure your desired point Coordinates by moving the telescope.

The displayed Coordinates automatically change according to your aiming point.

The Remote is a function of, so to speak, “Real-time offset”. If a reference point or offset point is measured, the Coordinates of your aiming point are calculated based on the reference plane.

There are three calculation methods of Cylindrical face, Fixed plane and Rotated plane. They are selected by the “[Preference](#)”. Refer to “[Remote method selection](#)”. The calculations are performed on the virtual planes.

MEASURE	
PN	POT3
PH	X.XXX m
X	
Y	
Z	

MEASURE	
PN	POT3
PH	X.XXX m
X	
Y	
Z	

To quit the Remote measurement, press [F1][REMOTE] twice again.

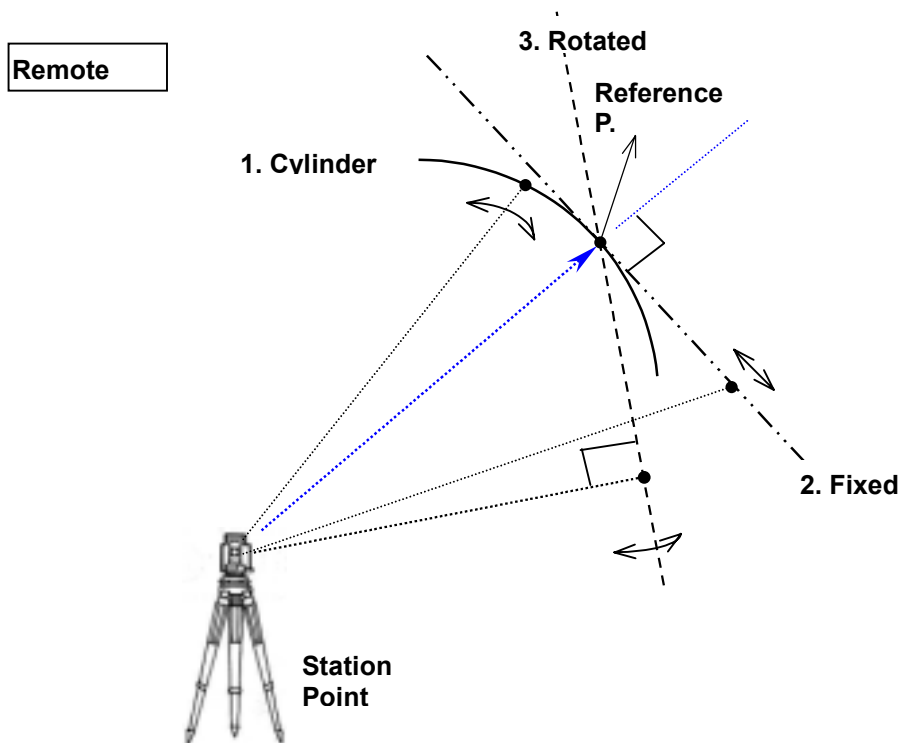

Three type menus can be used by pressing [F5][PAGE]. Another is following menu. The target type can be selected by pressing [F2][TARGET].

MEASURE		
PN	POT3	
PH		X.XXX m
X		
Y		
Z		
EDM	TARGET	PAGE

EDM settings can be selected by pressing [F1][EDM].

For example, change 1.PRIM. MEAS KEY (MEAS) to TRACK SHOT or TRACK CONT if you want to use tracking measurement with primary MEAS key (MEAS).

EDM SETTINGS	
1. PRIM. MEAS KEY	: MEAS. SHOT
2. SEC. MEAS KEY	: TRACK CONT
3. TRACK MIN DISP.	: COARSE
4. SHOT COUNT	: 1 TIME
5. SHOT INPUT	: 01 TIMES
	↑ ↓ ACCEPT

Coordinates display and Angle & Distance display

- 1) Press [F5][PAGE] twice to view [F3][ANG & DIST].
- 2) Press [F3][ANG & DIST] to view [F3][COORD.] and Angle and Distance values.
- 3) Press [F3][COORD.] to view [F3][ANG&DIST] and Coordinates.

MEASURE	ANG.& DISP.
PN	PN
PH	PH
X	H.angle
Y	V.angle
Z	H.dst
EDM	COORD
TARGET	DISP
ANG&DIST	
PAGE	

4.5.2 Offset

Press the [F2][OFFSET] to view the OFFSETS screen.

Offset enables you to work with Offsets. The following offsets are available.

OFFSETS	
1. RO:	0000.000 m
2. VO:	0000.000 m
3. DO:	0000.000 m
4. TO:	0000.000 m
	↑ ↓ ACCEPT

Press [ENT] to view the offset input window. Input the RO offset value by pressing keys. VO, DO and TO values are inputted in the same manner.

RO	
1. RO:	+0000.000m
2. VO:	+0000.000 m
3. DO:	+0000.000 m
4. TO:	+0000.000 m
	← → CLEAR

After input "TO" value, press [ENT] to view the MEASURE screen.
 (Or press [ESC] then press [ACCEPT].) The offset values are added to X,Y and Z values.

OFFSET	
PN	POT3
PH	m
X	+ offset.....
Y	+ offset.....
Z	+ offset.....

REMOTE | OFFSET | STATION | H ANGLE | PAGE

The input value of offset is cleared when you save the surveying point and step forward to the next surveying point.

RO: Radial Offset (RO: On the horizontal plane. Offset P: Along the line of measurement, thus along the slope)

Offset P: Offset Point

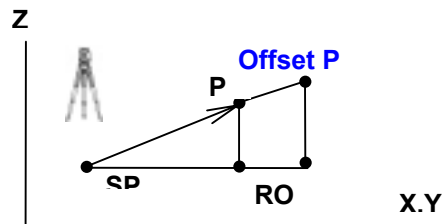

VO: Vertical Offset (Along the third axis)

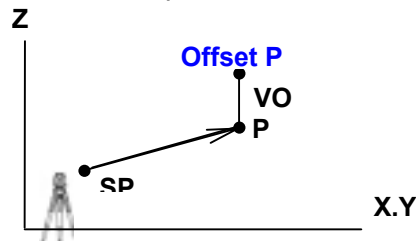

DO: Distance Offset (Along the line of measurement, thus along the slope)

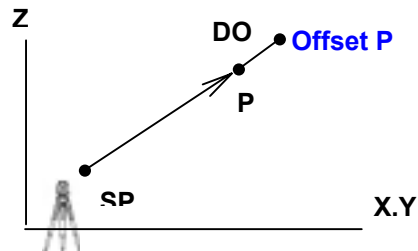

TO: Tangential offset (TO: On the horizontal plane, perpendicular to the horizontal line between Station and Point. Offset P: Along the slope)

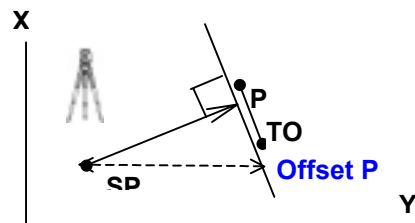

Coordinates display and Angle & Distance display

- 1) Press [F5][PAGE] twice to view [F3][ANG & DIST].
- 2) Press [F3][ANG & DIST] to view [F3][COORD.] and Angle and Distance values.
- 3) Press [F3][COORD.] to view [F3][ANG&DIST] and Coordinates.

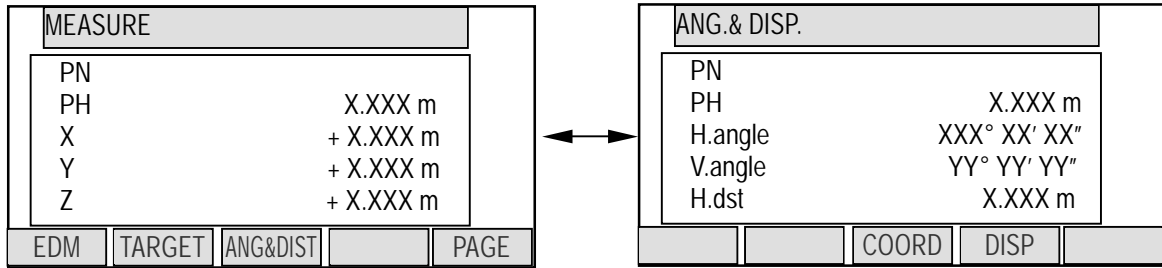

4.5.3 Station

Press [F3][STATION] to return to STATION POINT SETUP screen.

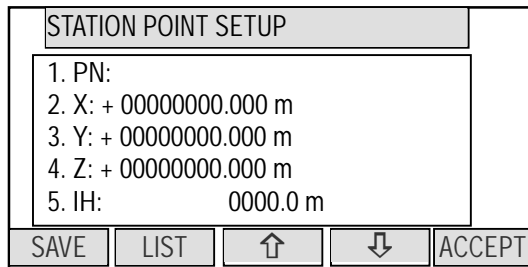

4.5.4 H. angle

Press [F4][H.ANGLE] to return to STATION POINT H. ANGLE SETUP screen.

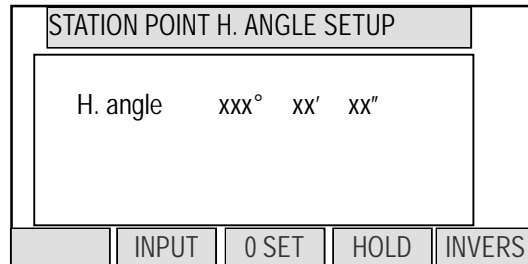

Press [ENT] to view the MEASURE screen.

4.6 Station setup [By Polar Coordinates]

The same Point Name of the plural polar points can be saved.

Press [F2][MEAS] of the PowerTopoLite screen to view the **MEASURE METHOD SELECTION** screen.

MEASURE METHOD SELECTION	
1.	RECTANGULAR COORD.
2.	POLAR COORD.

↑ ↓

Select 2. POLAR COORD. and press [ENT] to view the **STATION POINT SETUP** screen.

STATION POINT SETUP		
1. PN	:	
2. IH	:	0000.000 m
3. PC	:	
4. TEMP *		27° C
5. PRESS *		994 hpa

↓ ↑ ACCEPT

The ↑/↓ mark is used to scroll up / down. 6. PC is viewed by .

STATION POINT SETUP		
2. IH	:	0000.000 m
3. PC	:	
4. TEMP *		27° C
5. PRESS *		994 hpa
6. ppm *		

↑ ↓ ACCEPT

4.6.1 Point name, PN, input

Press [ENT] to view the PN screen.

PN	
1. PN	POT1
2. IH	: 0000.000 m
3. PC	:
4. TEMP *	27° C
5. PRESS *	994 hpa

← → BS CLEAR TO 123

4.6.2 IH, TEMP, PRESS, ppm and PC input

Input IH value.

Press [ENT].

IH	
1. PN	:
2. IH	: 0000.000 m
3. PC	:
4. TEMP *	27° C
5. PRESS *	994 hpa

← → BS CLEAR TO 123

Input the PC.

Press [ENT] to view and input the PC, Point code, screen.

If PointCode exists, you can easily select them from the list or edit one of them after pressing the [ENT]. For using Point Code List, please refer to "4.4. Point Code".

PC	
1. PN :	
2. IH :	0000.000 m
3. PC :	<input type="text"/>
4. TEMP * :	27° C
5. PRESS * :	994 hpa
<input type="button" value="←"/>	<input type="button" value="→"/>
<input type="button" value="BS"/>	<input type="button" value="CLEAR"/>
<input type="button" value="TO 123"/>	

If "PROCESS TYPE" is selected in "Action method selection", the inputted point data will be stored in the memory with [SAVE]. Then the panel "STATION POINT H.ANGLE SETUP" will be displayed without pressing [ACCEPT].

But, if "STRUCTURE TYPE" is selected in "Action method selection", it is necessary to press [ACCEPT] to proceed next panel.

Input the TEMP value.

is displayed.

STATION POINT SETUP	
1. PN :	XXXXX
2. IH :	000X.X00 m
3. PC :	
4. TEMP * :	<input type="text" value="Can't be changed"/>
5. PRESS * :	994 hpa
<input type="button" value="SAVE"/>	<input type="button" value="↑"/>
<input type="button" value="↓"/>	<input type="button" value="ACCEPT"/>

Press [ENT].

Input the PRESS value.

is displayed.

STATION POINT SETUP	
1. PN :	XXXXX
2. IH :	000X.X00 m
3. PC :	
4. TEMP * :	27 C
5. PRESS * :	<input type="text" value="Can't be changed"/>
<input type="button" value="SAVE"/>	<input type="button" value="↑"/>
<input type="button" value="↓"/>	<input type="button" value="ACCEPT"/>

Press [ENT].

Input ppm value.

is displayed.

STATION POINT SETUP	
2. IH :	000X.X00 m
3. PC :	
4. TEMP * :	27 C
5. PRESS * :	994 hpa
6. ppm * :	<input type="text" value="Can't be changed"/>
<input type="button" value="SAVE"/>	<input type="button" value="↑"/>
<input type="button" value="↓"/>	<input type="button" value="ACCEPT"/>

TEMP, PRESS and ppm input depend on the "Initial setting 1" (AUTO, ATM INPUT, ppm INPUT, NIL).

Above is shown at AUTO of the above.

4.7 Station Orientation

Press the [F5][ACCEPT] to view the **STATION POINT H. ANGLE SETUP** screen.
Input your desired H.angle.

Please, note that the rotation of the "H.angle" depend on the rotation setting of "[Coordinate axis definition](#)".

STATION POINT H. ANGLE SETUP				
H. angle xxx° xx' xx"				
	INPUT	0 SET	HOLD	INVERS

- [INVERS] key

If you want to calculate direction angle, Press [F5][INVERS] to jump to [INVERSE](#) function.
Input SP as station point, EP as back sight point.

INVERSE				
1. SP				
2. EP				
		↑	↓	

Result angle is set here automatically by pressing [ENT] at **RESULT OF INVERSE** screen.

RESULT OF INVERSE				
H.dst	0.0000m			
V.dst	0.0000m			
S.dst	0.0000m			
H.angle	xx° xx' xx"			

Press [ENT] after aiming back sight point.

Aim at the reference point and press [ENT] to view the **MEASURE** screen.

MEASURE				
PN	POT3			
PH	1.200 m			
H.angle	xxx° xx' xx"			
V.angle	xx° xx' xx"			
S.dst				
MEAS	SAVE	ME/SAVE	EDIT	PAGE

4.8 Measuring

Then, aim at the Target point and press the [F1][MEAS] to measure the distance.

MEASURE	
PN	POT3
PH	1.200 m
H.angle	xxx° xx' xx"
V.angle	xxx° xx' xx"
S.dst	xx.xxx m

MEAS	SAVE	ME/SAVE	EDIT	PAGE
------	------	---------	------	------

Press [F3][ME/SAVE] to measure and save the measured data.

Press [F2][SAVE] to save the measured data.

Press [F4][EDIT] to edit the PN, Point Name, PH, Prism Height and PC, Point Code. Press [ENT] to view each input window by pressing up or down arrow key, and input your desired point name or prism height or point code. Press [F5][ACCEPT] if the current PN, PH and PC are acceptable.

MEASURE	
1. PN:	POT5
2. PH:	000.000 m
3. PC:	

		↑	↓	ACCEPT
--	--	---	---	--------

PC, Point Code:

Press [ENT] to view and input the PC, Point code, screen.

If PointCode exists, you can easily select them from the list or edit one of them after pressing the [ENT]. For using Point Code List, please refer to ["4.4. Point Code"](#).

Press [F5][PAGE] to view another menu.

MEASURE	
PN	POT3
PH	1.200 m
H.angle	xxx° xx' xx"
V.angle	xxx° xx' xx"
S.dst	xx.xxx m

	OFFSET	STATION		PAGE
--	--------	---------	--	------

MEASURE	
PN	POT3
PH	1.200 m
H.angle	xxx° xx' xx"
V.angle	xxx° xx' xx"
S.dst	xx.xxx m

EDM	TARGET			PAGE
-----	--------	--	--	------

Station point setup can be changed by pressing [F3][STATION].

STATION POINT SETUP	
1. PN :	
2. IH :	0000.000 m
3. PC :	
4. TEMP * :	27° C
5. PRESS * :	994 hpa

SAVE		↑	↓	ACCEPT
------	--	---	---	--------

EDM settings can be selected by pressing [F1][EDM]

For example, change 1.PRIM. MEAS KEY (MEAS) to TRACK SHOT or TRACK CONT if you want to use tracking measurement with primary MEAS key (MEAS).

EDM SETTINGS	
↑	1. PRIM. MEAS KEY : MEAS. SHOT
	2. SEC. MEAS KEY : TRACK CONT
	3. TRACK MIN DISP. : COARSE
	4. SHOT COUNT : 1 TIME
	5. SHOT INPUT : 01 TIMES
	↑
	↓
	ACCEPT

4.9 Offset

RO: Radial Offset (RO: On the horizontal plane. Offset P: Along the line of measurement, thus along the slope)
 Offset P: Offset Point

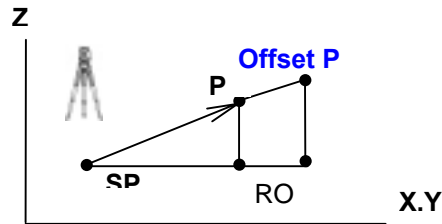

DO: Distance Offset (Along the line of measurement, thus along the slope)

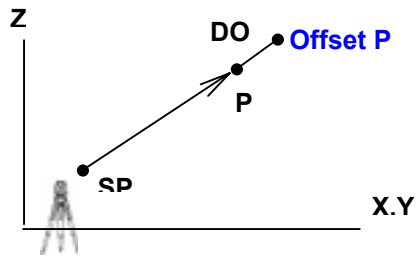

Press the [F2][OFFSET] to view the OFFSET screen.
 Offset enables you to work with Offset. The following offset are available.

OFFSETS	
1. RO:	+0000.000 m
2. DO:	+0000.000 m

Press [ENT] to view the offset input window. Input the RO offset value by pressing each keys.
 DO values are inputted in the same manner.

RO	
1. RO:	+0000.000 m
2. DO:	+0000.000 m

Press [ENT] and then [ACCEPT] to view the MEASURE screen. The S.dst (slope distance) is adjusted by inputted offset value.

OFFSET	
PN	POT3
PH	1.200 m
H.angle	xxx° xx' xx"
V.angle	xxx° xx' xx"
S.dst	OFFSET..... m

The input value of offset is cleared when you save the surveying point and step forward to the next surveying point.



5. VIEW AND EDIT

Stored data are displayed graphically, and the edit of the stored data is possible by this Function.

The Z Coordinate (the height) of the point is ignored in the graphical display of the point data.

Four menu items are available:

- Graphical view
- CREATE THE RECT. POINT
- EDIT THE RECT. DATA
- EDIT THE POLAR DATA

5.1 Graphical View

From the PowerTopoLite screen, press [F3][VIEW] to view its screen.

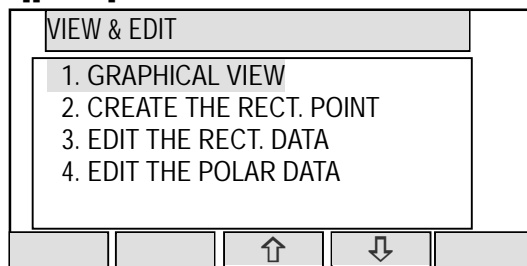

Press [ENT] to view the GRAPHICAL VIEW screen.

Points, Point names and their Graphics are displayed. The graphic is moved by pressing the arrow keys.

The Graphics are not displayed when points are not stored. Two or more points are needed.

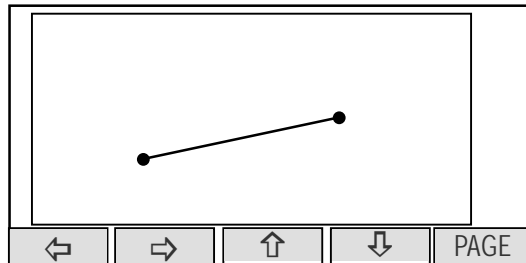

Press the [F5][PAGE] to view another menu.

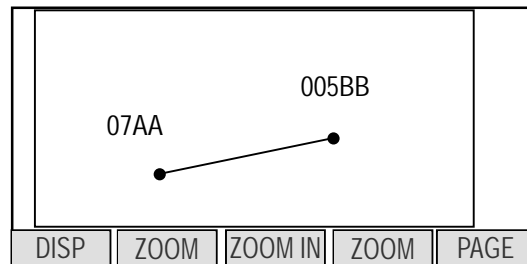

[DISP]: Each Graphic is displayed as following order by pressing this key.
Points → Points + Line → Points + Points names → Full

[ZOOM ALL]: Return to the ordinary Graphics size

[ZOOM IN]: Enlarge the Graphics size.

[ZOOM OUT]: Reduce the Graphics size.

5.2 Create the Rectangular Point

VIEW & EDIT				
1. GRAPHICAL VIEW				
2. CREATE THE RECT. POINT				
3. EDIT THE RECT. DATA				
4. EDIT THE POLAR DATA				
		↑	↓	

Select 2. CREATE THE RECT. POINT and press [ENT] to view the RECT. DATA EDIT screen.

RECT. DATA EDIT				
1. PN:				
2. X : + 00000000.000 m				
3. Y : + 00000000.000 m				
4. Z : + 00000000.000 m				
5. PC:				
SAVE	LIST	↑	↓	

Input the PN, X, Y, Z and PC.
Press [ENT] to save them.

RECT. DATA EDIT				
1. PN: XXXXX				
2. X : + 000000XX.000 m				
3. Y : + 000000XX.000 m				
4. Z : + 000000XX.000 m				
5. PC: XXXX				
SAVE	LIST	↑	↓	

Press [F2][LIST] to view the saved points.

RECT. DATA EDIT				
4 / 15				
PN x XXXXX				
X x+ 000000XX.000 m				
Y x+ 000000XX.000 m				
Z x + 000000XX.000 m				
DELETE	FIND PN	↑	↓	

The first line of the screen shows now displayed point and the total number of points.
Press [F1][DELETE] to delete your desired point.
Press [F2][FIND PN] to find your desired point by the PN input.

5.3 Edit the Data

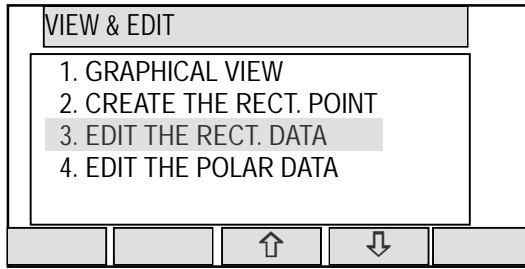

[RECT. DATA]

Select "3. EDIT THE RECT. DATA" and press [ENT] to view the RECT. DATA EDIT screen.

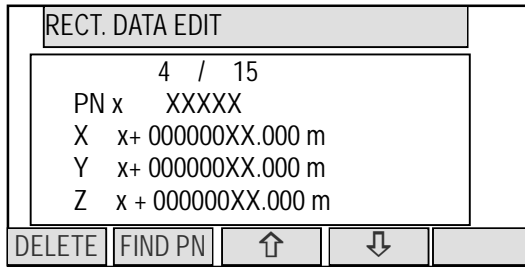

Your desired points are deleted and found as described above.

After selecting desired point with arrow key, press [ENT] to view the RECT. DATA EDIT screen to edit.

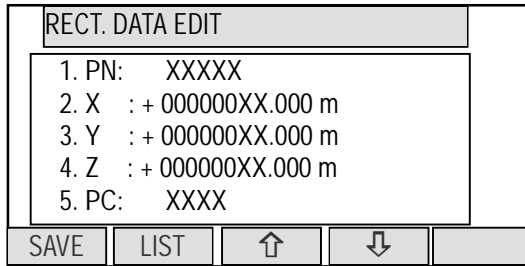

[POLAR DATA]

Select 3. EDIT THE RECT. DATA and press [ENT] to view the POLAR. DATA EDIT screen.

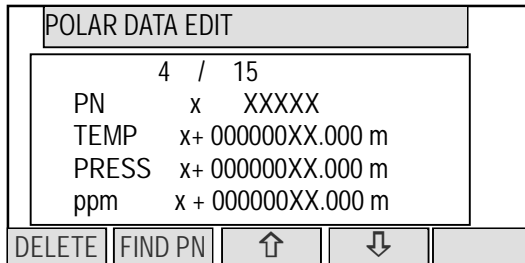

Your desired points are deleted and found as described above.

After selecting desired point with arrow key, press [ENT] to view the RECT. DATA EDIT screen to edit.

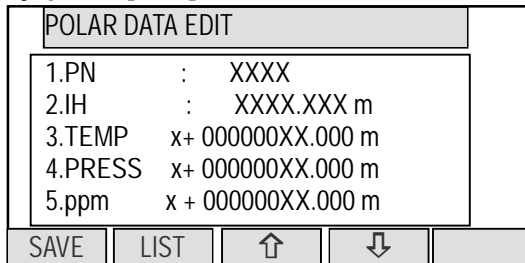

You can edit data and save it.

6. FREE STATIONING

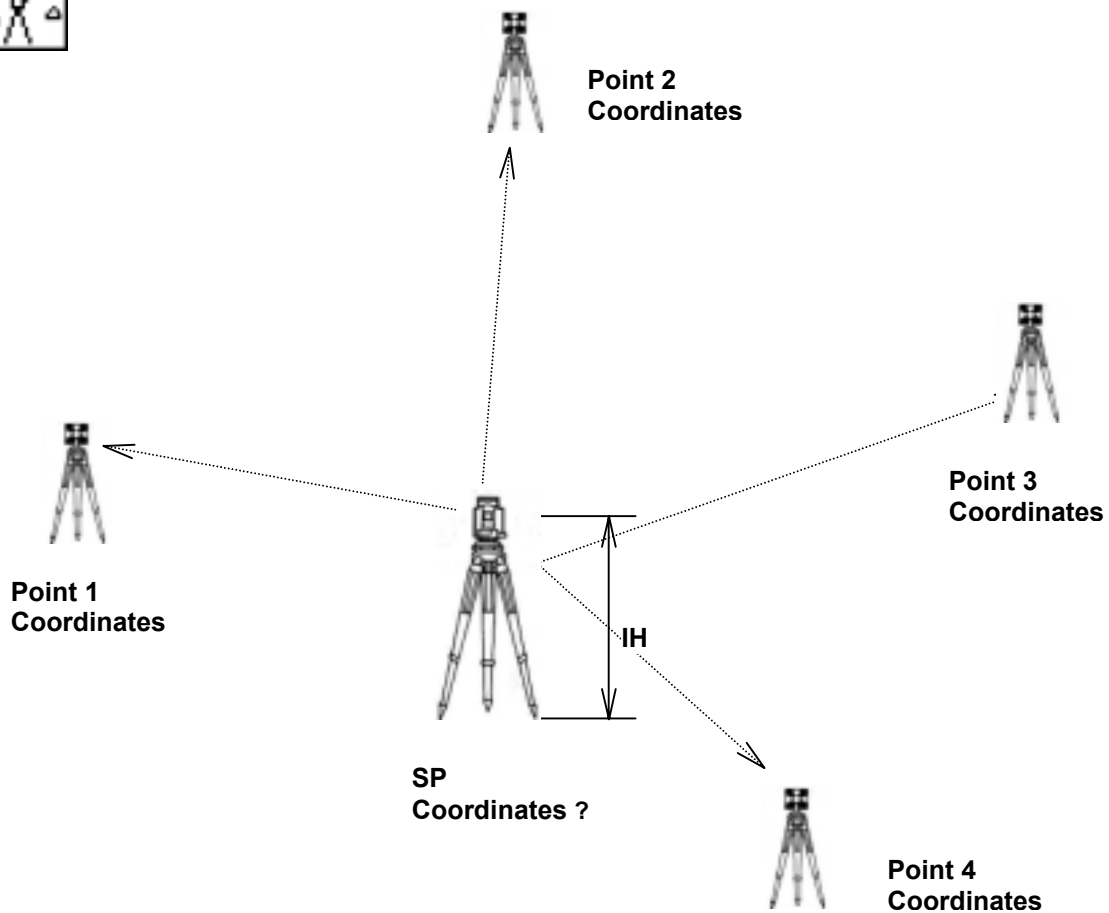

The Station point Coordinates is calculated from the plural known points. To gain the Coordinates, at least two H. angles and one distance or three H. angles are required. If not so, the error message of **“Not enough data to Calculate! 2 angles and 1 distance, 3 angles are required”** appears. First, input the height of the IH, Instrument height.

6.1 Stationing by more than 3 known points

4 known points stationing (For example)

Press [F4][FREE] of the PowerTopoLite screen to view the IH input screen.
Input the IH value.

IH				
0001.500m				
←	→	↑	↓	CLEAR

Aim at Point 1.

Press [ENT] to view the KNOWN POINT COORD. SETUP screen.

KNOWN POINT COORD. SETUP				
1. PN :				
2. X: + 00000000.000 m				
3. Y: + 00000000.000 m				
4. Z: + 00000000.000 m				
5. PH: 0000.000 m				
↓	SAVE	LIST	↑	↓
ACCEPT				

Press [ENT] to open the PN, X, Y, Z, IH and PC input window and input each.
Then, press [ENT] and [ACCEPT] to view the MEASURE screen.

MEASURE				
1	PN1			
PH				
H.angle				
V.angle				
H.dst				
MEAS	TARGET		EDIT	DISP

Press [ENT] to view the ADD/CALC. SELECTION MENU screen.
(Measuring is not needed. Just press [ENT].)

ADD/CALC. SELECTION MENU				
Do you want to add more points ?				
Press [ADD] to add more point.				
Press [CAL] to calculate.				
ADD				CALC

Press the [F1][ADD] to view the KNOWN POINT COORD. SETUP screen.
Aim at Point 2, 3 and 4.
In the same manner, input the values of Point 2,3 and 4.

KNOWN POINT COORD. SETUP				
1.PN : PN2				
2. X: + 00000000.000 m				
3. Y: + 00000000.000 m				
4. Z: + 00000000.000 m				
5. PH: 0000.000 m				
↓	SAVE	LIST	↑	↓
				ACCEPT

KNOWN POINT COORD. SETUP				
1.PN : PN3				
2. X: + 00000000.000 m				
3. Y: + 00000000.000 m				
4. Z: + 00000000.000 m				
5. PH: 0000.000 m				
↓	SAVE	LIST	↑	↓
				ACCEPT

KNOWN POINT COORD. SETUP				
1.PN : PN4				
2. X: + 00000000.000 m				
3. Y: + 00000000.000 m				
4. Z: + 00000000.000 m				
5. PH: 0000.000 m				
↓	SAVE	LIST	↑	↓
				ACCEPT

After entering values of PN4, press [ENT] twice to view the MEASURE and ADD/CALC SELECTION MENU.

ADD/CALC. SELECTION MENU				
Do you want to add more points ?				
Press [ADD] to add more point.				
Press [CAL] to calculate.				
ADD				CALC

Press the [F5][CALC] to view the RESULT COORD. OF STATIONING screen.

The Station Coordinates is displayed. Result coordinates of free stationing can be saved for Station setup after pressing [ACCEPT]. Horizontal angle of the result coordinates will be affected to the Station point for measuring.

RESULT COORD. OF STATIONING	
PN	
HA	0° 00' 05"
X	
Y	
Z	
NEXT	VIEW
	ACCEPT

Press [F1][NEXT] to view KNOWN POINT COORD. SETUP screen.

KNOWN POINT COORD. SETUP	
1. PN :	
2. X: +	00000000.000 m
3. Y: +	00000000.000 m
4. Z: +	00000000.000 m
5. PH:	0000.000 m
SAVE	LIST
	ACCEPT

DEVIATIONS OF THE POINT: Four points or more points are needed to view this.

Press [ENT] to view the DEVIATIONS OF THE POINT screen. The deviations of X, Y and Z coordinate of each point are displayed. For each point, you can decide if you want to accept or reject the point.

PN: Current point number
dX: Deviation on the X value
dY: Deviation on the Y value
dZ: Deviation on the Z value

DEVIATIONS OF THE POINT	
PN	POT4
d HA	0° 00' 05"
dX	+ 0.000 m
dY	+ 0.000 m
dZ	+ 0.000 m
REJECT	ACCEPT

6.2 Stationing by two known points

(One point must be measured at least to gain the Station Coordinates.)

Press [F4][FREE] of the PowerTopoLite screen to view the IH input screen.

Input the IH value.

IH				
0001.500m				
←	→			CLEAR

Aim at the Point 1.

Press [ENT] to open the PN, X, Y, Z, PH and PC input window and input each value.

KNOWN POINT COORD. SETUP				
1. PN :				
2. X: + 00000000.000 m				
3. Y: + 00000000.000 m				
4. Z: + 00000000.000 m				
5. PH: 0000.000 m				
↓				
SAVE	LIST	↑	↓	ACCEPT

Then, press [ENT] to view the MEASURE screen.

MEASURE				
1 POT1				
PH				
H.angle				
V.angle				
H.dst				
MEAS	TARGET		EDIT	DISP

Press [ENT] to view the ADD/CALC. SELECTION MENU screen.

ADD/CALC. SELECTION MENU				
Do you want to add more points ?				
Press [ADD] to add more points.				
Press [CAL] to calculate.				
ADD				CALC

Press [F1][ADD] to view the SET UP THE KNOWN POINT screen.

In the same manner, aim at the Point 2.

Press [ENT] to open the PN, X, Y, Z, PH and PC input window and input each value.

SET UP THE KNOWN POINT				
1. PN :				
2. X: + 00000000.000 m				
3. Y: + 00000000.000 m				
4. Z: + 00000000.000 m				
5. PH: 0000.000 m				
SAVE	LIST	↑	↓	ACCEPT

Then, press [ENT] and [ACCEPT] to view the MEASURE screen.

MEASURE				
1 POT1				
HI				
H.angle				
V.angle				
H.dst				
MEAS	TARGET		EDIT	DISP

Press the [F1][MEAS] to measure the distance.

Press [ENT] to view the ADD/CALC. SELECTION MENU screen.

ADD/CALC. SELECTION MENU				
Do you want to add more points ?				
Press [ADD] to add more points.				
Press [CAL] to calculate				
ADD				CALC

Press [ENT] to view the RESULT COORD. OF STATIONING

The Station Coordinates is displayed. . Result coordinates of free stationing can be saved for Station setup after pressing [ACCEPT]. Horizontal angle of the result coordinates will be affected to the Station point for measuring.

RESULT COORD. OF STATIONING				
PN				
HA 0° 00' 05"				
X				
Y				
Z				
NEXT		VIEW		ACCEPT

Note:

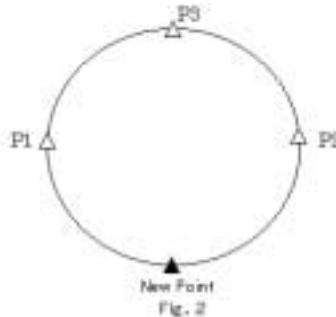
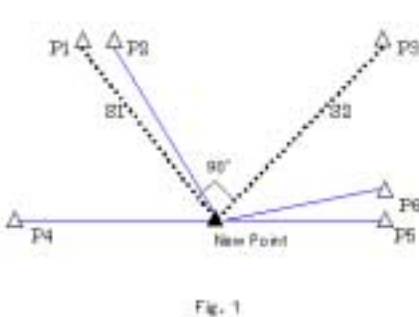

As illustrated Fig. 1, It is optimal to choose the known points P1 and P3.

The angle of two known points should be set up a machine so that it may become 90 degrees.

Please install a machine in a position where distance s1 and s2 becomes as same the length as possible.

The accuracy of a calculation result falls as follows,

- 1) When P1 and P2 are chosen for a known point. (The interior angle between known points is extremely small)
- 2) When P4 and P6 are chosen for a known point. (The interior angle between known points is extremely large)
- 3) When P4 and P5 are chosen for a known point. (The interior angle between known points is 180 degrees)
- 4) When the distance from a new point to a known point is extremely short or extremely long.
- 5) When a new point (station point) and three or more known points are arranged on the same circumference. (Refer to Fig. 2)

✘ When searching for a new point by a FREESTATION and surveying by installing a machine in the point, accuracy may not be stabilized compared with the case where a machine is installed on a known point. In the work which needs a high-precision survey, we cannot recommend you.



7. STAKE OUT

From the known Station point and Direction angle, the Coordinates for the Stakeout are obtained.

7.1 STAKE OUT

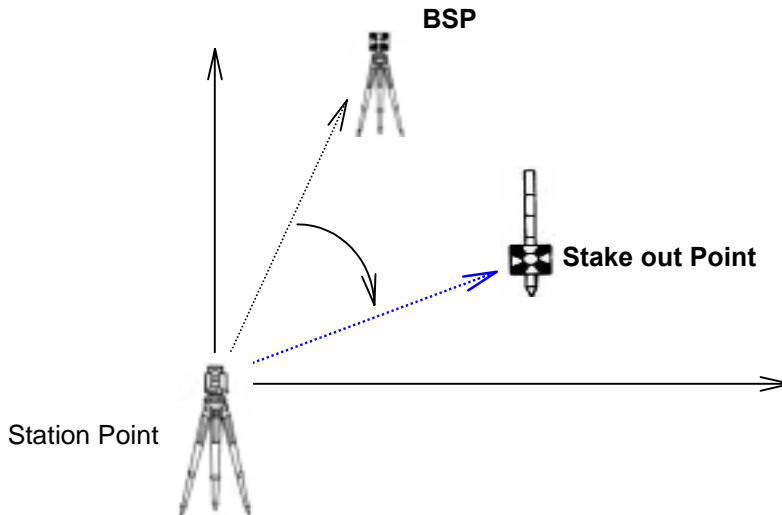

Press [F1][STAK] to view the **STAKEOUT METHOD SELECTION** screen.

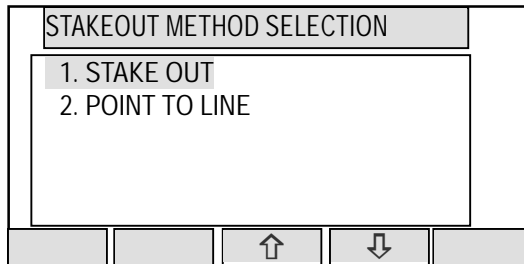

Select 1.STAKE OUT and press [ENT] to view the **STATION POINT SETUP** screen.

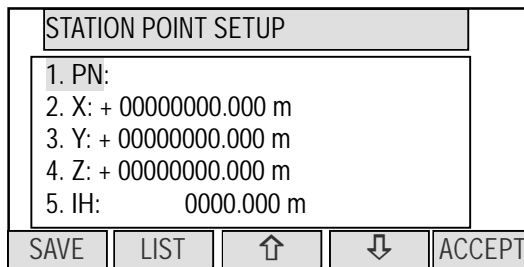

Open the PN, X, Y, Z, IH and PC input window and input each. Save the data by pressing [F1][SAVE].

Press [ENT] to view **STATION POINT H ANGLE SETUP** screen.

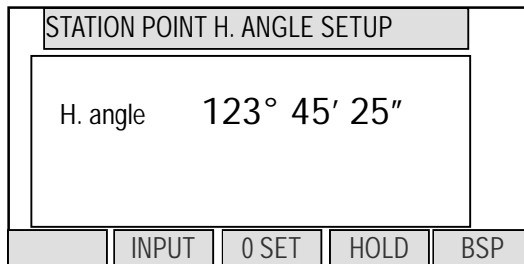

Input the H. angle by pressing [F2][INPUT], [F3][0SET] and [F4] [HOLD] or Backsight Coordinates by pressing [F5][BSP].

Pressing [F2][INPUT]

H.angle	
H. angle	XXX° XX' XX"
[←]	[→]
[]	[CLEAR]

Pressing [F5][BSP]

BSP SETUP	
1. PN:	
2. X: + 00000000.000 m	
3. Y: + 00000000.000 m	
4. Z: + 00000000.000 m	
5. PC:	
[SAVE]	[LIST]
[↑]	[↓]
[ACCEPT]	

Press [ENT] to view the STAKEOUT COORD. SETUP screen.

Open the PN, X, Y, Z, PH and PC input window and input each.

STAKEOUT COORD. SETUP	
1. PN:	
2. X: + 00000000.000 m	
3. Y: + 00000000.000 m	
4. Z: + 00000000.000 m	
5. PH: 0000.000 m	
[SAVE]	[LIST]
[↑]	[↓]
[ACCEPT]	

Save the data by pressing [F1][SAVE].

Press [ENT] or [ACCEPT] to view the STAKEOUT screen.

STAKEOUT	
PN	POT4
PH	X. XXX m
D H.angle	XXX° XX' XX"
D V.angle	XX° XX' XX"
D H.dst	
D X	
D Y	
D Z	
[MEAS]	[TARGET]
[]	[PAGE]

Aim at the Stake out point and press the [F1][MEAS] to begin the Stake Out.

Deviation of each value is displayed.

Form of the screen to display deviation of the Stake Out can be changed by the selections of the "Compare method selection" in "PREFERENCE" setting.

To display all information at once, select "ALL IN ONE INFO."

To display information with larger character, select "LARGE CHARACTER".

STAKEOUT	
PN	POT4
PH	X. XXX m
D H.angle	XXX° XX' XX"
D V.angle	XX° XX' XX"
D H.dst	
D X	+X. XXX m
D Y	-X. XXX m
D Z	+X. XXX m
[MEAS]	[TARGET]
[]	[NEXT]
[PAGE]	

STAKEOUT	
PN	POT4
PH	X. XXX m
D H.angle	XXX° XX' XX"
D V.angle	- X° XX' XX"
D H. dist.	- m
[MEAS]	[TARGET]
[]	[SCROLL]
[]	[NEXT]
[PAGE]	

Press [F5][PAGE] to view another screen.

STAKEOUT	
PN	POT4
PH	X. XXX m
D H.angle	XXX° XX' XX"
D V.angle	XX° XX' XX"
D H.dst	
D X	+X. XXX m
D Y	-X. XXX m
D Z	+X. XXX m
[RECT.M]	[STATION]
[H.ANGLE]	[EDIT]
[PAGE]	

STAKEOUT	
PN	POT4
PH	X. XXX m
D H.angle	XXX° XX' XX"
D V.angle	- X° XX' XX"
D H. dist.	- m
[RECT.M]	[STATION]
[H.ANGLE]	[EDIT]
[PAGE]	

If you select "LARGE CHARACTER", the information is shown with two screens and these screens and the Graphics screen can be switched by [ENT].

STAKEOUT	
PN	POT4
PH	X. XXX m
D X	+X. XXX m
D Y	-X. XXX m
D Z	+X. XXX m
MEAS	TARGET SCROLL NEXT PAGE

Press [ENT] to view the Graphics screen.

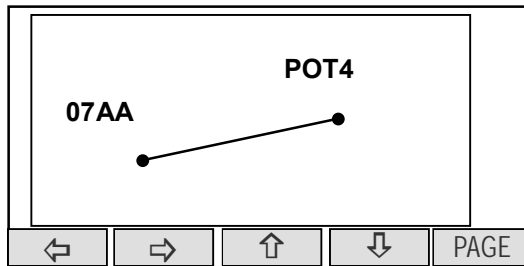

Press the [F5][PAGE] to view another menu.
Press [ENT] to go back to the STAKEOUT screen.

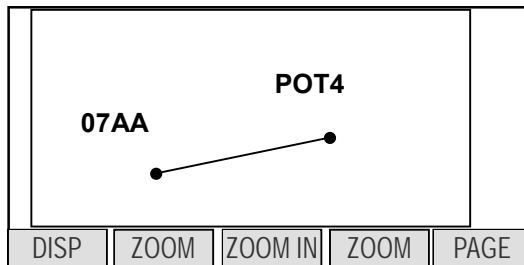

Press the [F1][RECT.M] to view the MEASURE screen.

MEASURE	
PN	
PH	0.000m
X	
Y	
Z	
RECT.M	STATION H.ANGLE PAGE

Press the [F4][NEXT] to carry out staking out for the next point.
Press the [F5][PAGE] to view the other MEASURE screen.

MEASURE	
PN	POT4
PH	X. XXX m
D H.angle	XXX° XX' XX"
D V.angle	XX° XX' XX"
D H.dst	
D X	m
D Y	m
D Z	m
REMOTE	OFFSET STATION H.ANGLE PAGE

Refer to the "[4.5 Remote, Offset and H.angle](#)" function.
Press the [F5][PAGE] to view the other MEASURE menu.

MEASURE	
PN	
PH	
X	
Y	
Z	
MEAS	TARGET SCROLL NEXT PAGE

7.2 POINT TO LINE

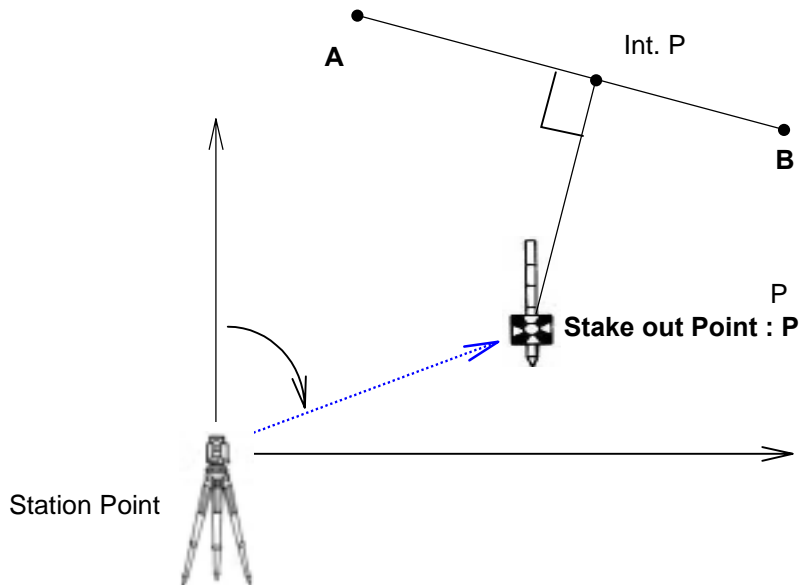

You have to select the point A and B. The distance between the two points A and B has to be at least 1 m. The two points A and B define a line and during Stake out, PTL shows the deviations from the Stake out point, P, to the line A-B. (At above STAKEOUT screen)
 Select 2. POINT TO LINE and press [ENT] to view STATION POINT SETUP screen..

Open the PN, X, Y, Z, IH and PC input window and input each. Press [ENT] to view the STATION POINT H. ANGLE SETUP screen.

STATION POINT SETUP	
1. PN	PO1
2. X:	+ 00000000.000 m
3. Y:	+ 00000000.000 m
4. Z:	+ 00000000.000 m
5. IH:	000.000 m
↓	
SAVE	LIST
↑	↓
ACCEPT	

Input the H. angle.

STATION POINT H ANGLE SETUP	
H. angle	123° 45' 25"
↓	
INPUT	0 SET
HOLD	BSP

Aim at the reference point and press [ENT] to view POINT A COORD.SETUP screen.

POINT A COORD.SETUP	
1. PN	PO2
2. X:	+ 00000000.000 m
3. Y:	+ 00000000.000 m
4. Z:	+ 00000000.000 m
5. PH:	0000.000 m
↓	
SAVE	LIST
↑	↓
ACCEPT	

Open the PN, X, Y, Z, PH and PC input window and input each of the Point A and press [ENT].
 Open the PN, X, Y, Z, PH and PC input window and input each of the Point B.

POINT B COORD. SETUP	
1. PN	PO3
2. X:	+ 00000000.000 m
3. Y:	+ 00000000.000 m
4. Z:	+ 00000000.000 m
5. PH:	0000.000 m
SAVE	LIST
↑	↓
ACCEPT	

Press [ENT] to view the POINT TO LINE screen.

POINT TO LINE	
A ->B	+0.000 m
SOP -> A-B	
Int.P -> A	
Int.P -> B	
MEAS	TARGET
	NEXT
	PAGE

Press [F1][MEAS] to measure.
 Each distance is displayed.

POINT TO LINE	
A ->B	
SOP -> A-B	
Int.P -> A	
Int.P -> B	
MEAS	TARGET
	NEXT
	PAGE

A → B: Distance between Point A and B. This is always positive.

P → A - B Distance between Int. P and P, This is positive or negative as shown below.
 Int.P: Intersection point
 P: SOP, Stake Out Point

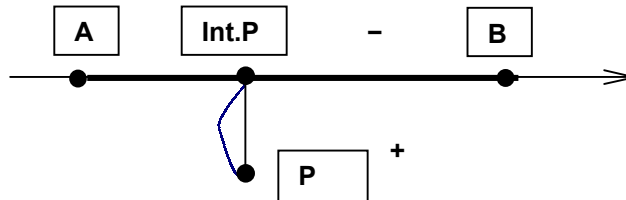

Int. P → A Distance between Int. P and A, This is positive or negative.

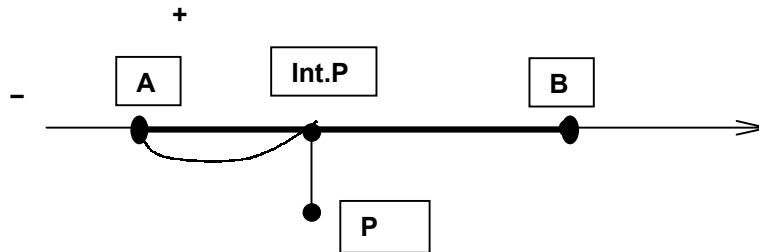

Int. P → B Distance between Int. P and B, This is positive or negative.

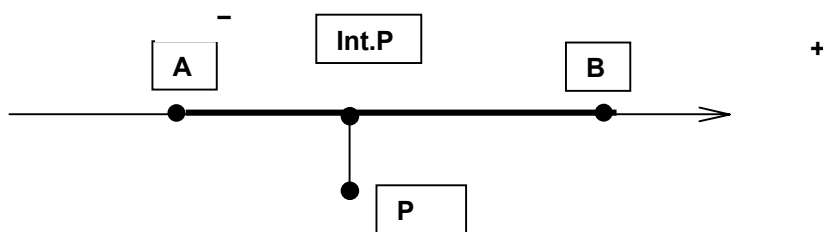

The arrow direction is positive.
Press [ENT] to display the Graphics.
Graphics are moved by each arrow key.

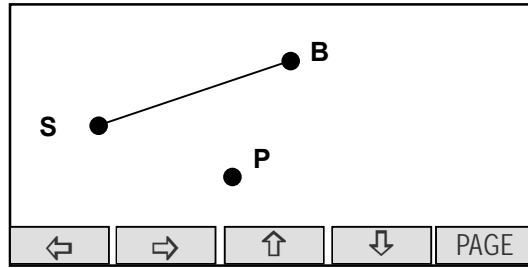

Press the [F5][PAGE] to change the menu.

Refer to the Graphical view of the [“5. VIEW AND EDIT”](#) function concerning each key function.

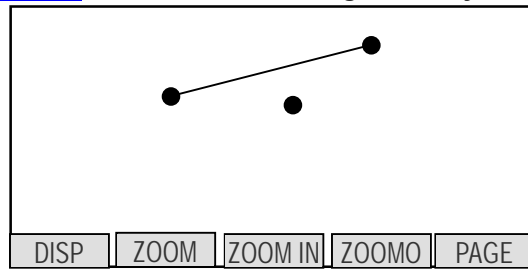



8. CALCULATIONS

The following calculations are available:

- COGO
- 2D SURFACE
- 3D SURFACE & VOLUME
- REM

8.1 COGO

The following COGO functions are available:

- Inverse
- Points Coordinates
- Circle Radius
- Line-Arc Intersection
- Line-Line Intersection
- Arc-Arc Intersection
- Distance Offset
- Point Distance Offset
- Arc Distance Offset

8.1.1 INVERSE

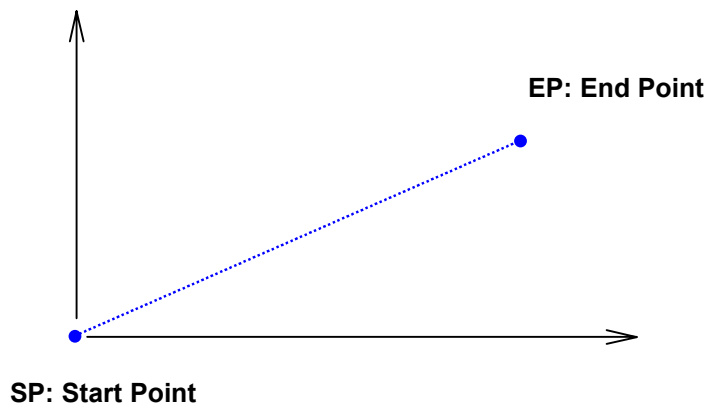

From the given two points Coordinates, the Direction angle and distance are calculated.

Input: Coordinates of two points

Output: Horizontal distance, Vertical distance between the points and Direction of the line defined by the two points

From the PowerTopoLite screen, press [F2][CALC] to view CALCULATION screen.

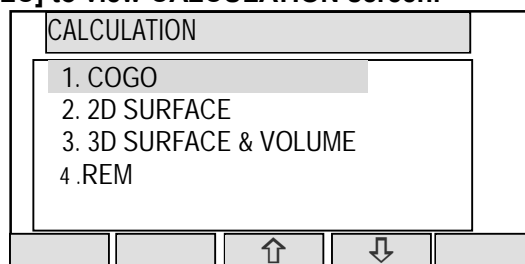

Select 1.COGO and press [ENT] to view the COGO screen.

COGO				
1. INVERSE				
2. POINT COORDINATES				
3. CIRCLE RADIUS				
4. LINE-ARC INTERSECTION				
5. LINE-LINE INTERSECTION				
		↑	↓	

Select the 1. INVERSE and press [ENT] to view INVERSE screen.

INVERSE				
1. SP				
2. EP				
		↑	↓	

A. Start point input
(Input the PN, Coordinates and PC of the Start point.)

Select 1. SP and press [ENT] to view SP screen.

SP				
1. PN:				
2. X: + 00000000.000 m				
3. Y: + 00000000.000 m				
4. Z: + 00000000.000 m				
5. PC:				
SAVE	LIST	↑	↓	ACCEPT

● [LIST] key

All stored points can be displayed as follows by pressing [F2][LIST].
Press [F2][LIST] to view POINT SELECTION FROM THE LIST screen.

POINT SELECTION FROM THE LIST				
1 / 15				
1. PN:POT1				
2. X: + 00000000.000 m				
3. Y: + 00000000.000 m				
4. Z: + 00000000.000 m				
		↑	↓	
DELETE	FIND PN	↑	↓	

Press [ENT] to open the SP input screen.

SP				
1. PN:				
2. X: + 00000000.000 m				
3. Y: + 00000000.000 m				
4. Z: + 00000000.000 m				
5. PC:				
SAVE	LIST	↑	↓	ACCEPT

Input your desired point name by pressing each keys, and press [ENT] to view START PT 1 screen.
Press [ENT] to open the X coordinate input screen.

X				
1. PN: POT1				
2. X: + 00000000.000 m				
3. Y: + 00000000.000 m				
4. Z: + 00000000.000 m				
5. PC:				
←	→			CLEAR

Input your desired value by pressing each keys and press [ENT] to go Y coordinate.

SP				
1. PN:				
2. X: + 00000000.000 m				
3. Y: + 00000000.000 m				
4. Z: + 00000000.000 m				
5. PC:				
SAVE	LIST	↑	↓	ACCEPT

Press [ENT] to open the Y coordinate input screen and input.

Y				
1. PN: POT1				
2. X: + 00000000.000 m				
3. Y: + 00000000.000 m				
4. Z: + 00000000.000 m				
5. PC:				
←	→			CLEAR

Press [ENT] to open the Z coordinate input screen and input.

Z				
1. PN: POT1				
2. X: + 00000000.000 m				
3. Y: + 00000000.000 m				
4. Z: + 00000000.000 m				
5. PC:				
←	→			CLEAR

Press [ENT] to open the PC input screen and input.

PC				
1. PN: POT1				
2. X: + 00000000.000 m				
3. Y: + 00000000.000 m				
4. Z: + 00000000.000 m				
5. PC: <input type="text"/>				
←	→			CLEAR

B. End point coordinates input
 (Input the PN , Coordinates and PC of the End point.)

After PC input, EP screen is viewed.

EP				
1. PN:				
2. X: + 00000000.000 m				
3. Y: + 00000000.000 m				
4. Z: + 00000000.000 m				
5. PC:				
SAVE	LIST	↑	↓	ACCEPT

Input the PN, X, Y, Z Coordinates and PC name of the End point.

Z				
1. PN: POT1				
2. X: + 00000000.000 m				
3. Y: + 00000000.000 m				
4. Z: + 00000000.000 m				
5. PC:				
←	→			CLEAR

Press [ENT] to view the RESULT OF INVERSE screen.

RESULT OF INVERSE	
H.dst	0.0000 m
V.dst	0.0000 m
S.dst	0.0000 m
H.angle	xxx° xx' xx"

ESC				ENT
-----	--	--	--	-----

C. Another End point Coordinates input

Input the PN, X, Y, Z Coordinates and PC name of another End point, and the another inverse result can be performed.

INVERSE	
1. SP	
2. EP	

		↑	↓	
--	--	---	---	--

EP	
1. PN: POT3	
2. X: + 00000000.000 m	
3. Y: + 00000000.000 m	
4. Z: + 00000000.000 m	
5. PC:	

SAVE	LIST	↑	↓	ACCEPT
------	------	---	---	--------

RESULT OF INVERSE	
H.dst	0.0000 m
V.dst	0.0000 m
S.dst	0.0000 m
H.angle	xxx° xx' xx"

ESC				ENT
-----	--	--	--	-----

8.1.2 POINTS COORDINATES

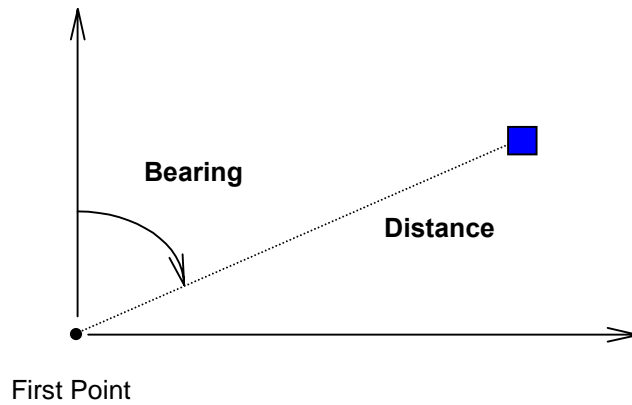

A point Coordinates is calculated from a known point Coordinates and the Distance and Horizontal angle of the second point.

Input: Coordinates of a known point, Distance and Horizontal angle of the second point
Output: Coordinates of the second point

From the PowerTopoLite screen, press [F2][CALC] to view the CALCULATION screen.

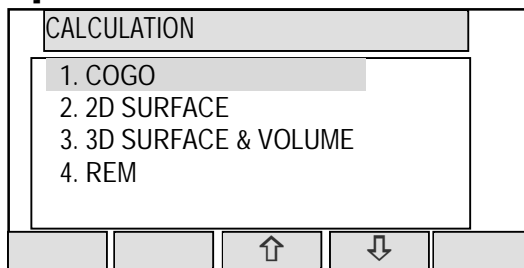

Select 1.COGO and press [ENT] to view the COGO screen.

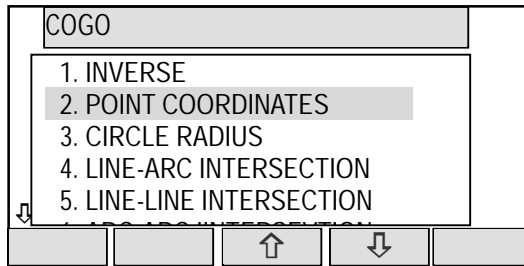

8.1.2.1 Point Coordinates, Distance and H. angle

Select the 2. POINT COORDINATES and press [ENT] to view POINT COORDINATES screen.

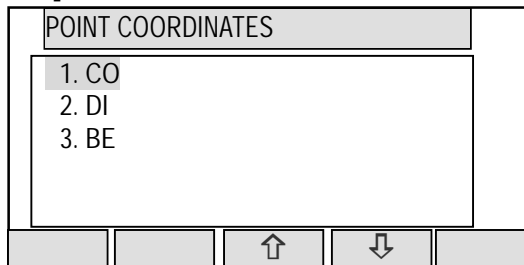

Select 1. CO and press [ENT] to view CO screen.

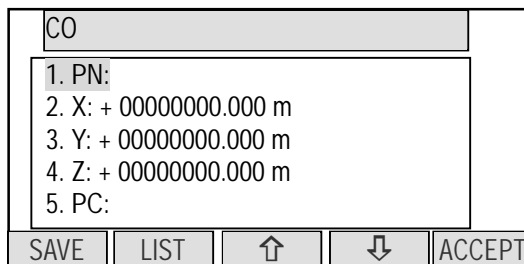

Press [ENT] to open the PN input screen.

PN				
1. PN: <input type="text"/>				
2. X: + 00000000.000 m				
3. Y: + 00000000.000 m				
4. Z: + 00000000.000 m				
5. PC:				
<input type="button" value="←"/>	<input type="button" value="→"/>	<input type="button" value="BS"/>	<input type="button" value="CLEAR"/>	<input type="button" value="TO 123"/>

Input your desired point name by pressing keys and press [ENT] to view X screen.

CO				
1. PN:				
2. X: + 00000000.000 m				
3. Y: + 00000000.000 m				
4. Z: + 00000000.000 m				
5. PC:				
<input type="button" value="SAVE"/>	<input type="button" value="LIST"/>	<input type="button" value="↑"/>	<input type="button" value="↓"/>	<input type="button" value="ACCEPT"/>

Press [ENT] to open the X coordinate input screen.

X				
1. PN: POI1				
2. X: <input type="text" value="+ 00000000.000 m"/>				
3. Y: + 00000000.000 m				
4. Z: + 00000000.000 m				
5. PC:				
<input type="button" value="←"/>	<input type="button" value="→"/>	<input type="button" value=""/>	<input type="button" value=""/>	<input type="button" value="CLEAR"/>

Input your desired value by pressing each keys and press [ENT] to go Y coordinate.

CO				
1. PN:				
2. X: + 00000000.000 m				
3. Y: + 00000000.000 m				
4. Z: + 00000000.000 m				
5. PC:				
<input type="button" value="SAVE"/>	<input type="button" value="LIST"/>	<input type="button" value="↑"/>	<input type="button" value="↓"/>	<input type="button" value="ACCEPT"/>

Press [ENT] to open the Y coordinate input screen.

Y				
1. PN: POT1				
2. X: + 00000000.000 m				
3. Y: <input type="text" value="+ 00000000.000 m"/>				
4. Z: + 00000000.000 m				
5. PC:				
<input type="button" value="←"/>	<input type="button" value="→"/>	<input type="button" value=""/>	<input type="button" value=""/>	<input type="button" value="CLEAR"/>

In the same manner, input your desired value by pressing each keys and press [ENT] to open the Z coordinate input screen.

Z				
1. PN: POT1				
2. X: + 00000000.000 m				
3. Y: + 00000000.000 m				
4. Z: <input type="text" value="+ 00000000.000 m"/>				
5. PC:				
<input type="button" value="←"/>	<input type="button" value="→"/>	<input type="button" value=""/>	<input type="button" value=""/>	<input type="button" value="CLEAR"/>

Input your desired value by pressing each keys and press [ENT] to open the PC, Point Code, input screen.

PC				
1. PN: POT1				
2. X: + 00000000.000 m				
3. Y: + 00000000.000 m				
4. Z: + 00000000.000 m				
5. PC: <input type="text"/>				
←	→			CLEAR

Input your desired PC by pressing each keys, and press [ENT] to view DI screen.

DISTANCE				
<input type="text"/>				
0000.000m				
←	→			CLEAR

Input your desired value and press [ENT] to open the H. ANGLE input window.

H. angle				
<input type="text"/>				
000° 00' 00"				
←	→			CLEAR

Input your desired value to view the RESULT OF COORD. CALCULATE screen.
The second point Coordinates are displayed by plus or minus from the known Coordinates.

RESULT OF COORD. CALCULATE				
X +0.000m				
Y +0.000m				
Z +0.000m				
ESC				ENT

Press [ENT] to view the following screen.

RESULT OF COORD. CALCULATE				
1. PN:				
2. X: + XXXXXXXX.XXX m				
3. Y: + XXXXXXXX.XXX m				
4. Z: + XXXXXXXX.XXX m				
5. PC:				
SAVE		↑	↓	ACCEPT

The PN, X, Y, Z and PC are viewed and can be edited.
If all items are OK, press [F1][SAVE] or [F5][ACCEPT] to save them.

8.1.2.2 Distance and H. angle

In the same manner, the values of Distance and H. angle are inputted as follows and the second point Coordinates are displayed.

POINT COORDINATES	
1. CO	
2. DI.	
3. BE	

↑ ↓

Select 2. DI and press [ENT] to view DI screen.

DISTANCE	
0000.000m	

← → ↑ ↓ CLEAR

Input your desired value and press [ENT] to open the H. ANGLE input window.

H.angle	
000° 00' 00"	

← → CLEAR

Input your desired value to view the RESULT OF COORD. CALCULATE screen.
The second point Coordinates are displayed by plus or minus from the known Coordinates.

RESULT OF COORD. CALCULATE	
X	+0.000m
Y	+0.000m
Z	+0.000m

ESC ENT

Press [ENT] to view the following screen.

RESULT OF COORD. CALCULATE	
1. PN:	
2. X:	+ XXXXXXXX.XXX m
3. Y:	+ XXXXXXXX.XXX m
4. Z:	+ XXXXXXXX.XXX m
5. PC:	

SAVE LIST ↑ ↓ ACCEPT

The PN, X, Y, Z and PC are viewed and can be edited.
If all items are OK, press [F1][SAVE] or [F5][ACCEPT] to save them.

8.1.2.3 H. angle input

In the same manner, only the value of H. angle is inputted as follows, and the second point Coordinates are displayed.

POINT COORDINATES	
1. CO	
2. DI	
2. DI	

↑ ↓

Select 3. BE and press [ENT] to view H. ANGLE screen.

Input H. angle and press [ENT] to view the RESULT OF COORD. CALCULATE screen.

H. ANGLE	
000° 00' 00"	

← → ↑ ↓ CLEAR

The second point Coordinates are displayed by plus or minus from the known Coordinates.

RESULT OF COORD. CALCULATE	
X	+0.000m
Y	+0.000m
Z	+0.000m

ESC ENT

Press [ENT] to view the following screen.

RESULT OF COORD. CALCULATE	
1. PN:	
2. X: +	XXXXXXXX.XXX m
3. Y: +	XXXXXXXX.XXX m
4. Z: +	XXXXXXXX.XXX m
5. PC:	

SAVE LIST ↑ ↓ ACCEPT

The PN, X, Y, Z and PC are viewed and can be edited.

If all items are OK, press [F1][SAVE] or [F5][ACCEPT] to save them.

8.1.3 CIRCLE RADIUS

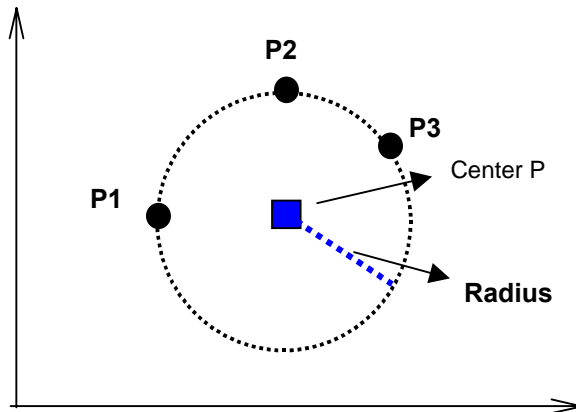

The center point and radius of the circle drawn by three points are calculated by this function. You can store calculated center point.

Input: 3 points

Output: Center point of the arc
Radius of the arc

From the PowerTopoLite screen, press [F2][CALC] to view the CALCULATION screen.

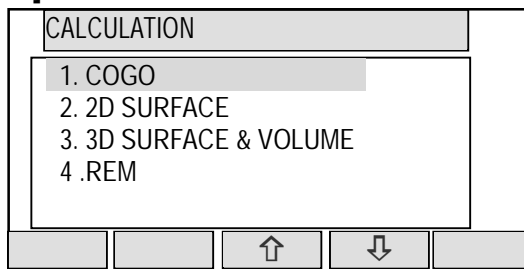

Select 1.COGO and press [ENT] to view the COGO screen.

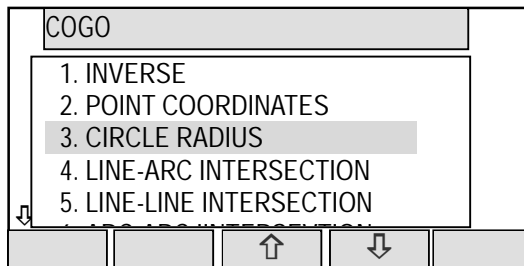

Select the 3. CIRCLE RADIUS and press [ENT] to view CIRCLE RADIUS screen.

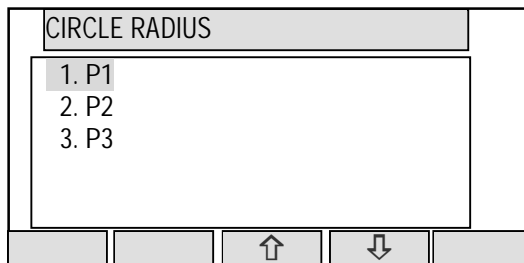

Select 1. P1 and press [ENT] to view P1 screen.

P1				
1. PN:				
2. X: + 00000000.000 m				
3. Y: + 00000000.000 m				
4. Z: + 00000000.000 m				
5. PC:				
SAVE	LIST	↑	↓	ACCEPT

Input PN (Point Name), X, Y, Z, and PC (Point Code) of P1 point or import from the memory of rectangular coordinate as P1 by [F2][LIST].

If you finish the input of P1 value, press [F5][ACCEPT]. Then you go to P2 input screen.

P2				
1. PN:				
2. X: + 00000000.000 m				
3. Y: + 00000000.000 m				
4. Z: + 00000000.000 m				
5. PC:				
SAVE	LIST	↑	↓	ACCEPT

Input P2 data like input of P1. If you finish the input of P2, press [F5][ACCEPT]. Then you go to P3 input screen.

P3				
1. PN:				
2. X: + 00000000.000 m				
3. Y: + 00000000.000 m				
4. Z: + 00000000.000 m				
5. PC:				
SAVE	LIST	↑	↓	ACCEPT

If you finish the input of P3, press [F5][ACCEPT]. Then you go to RESULT OF CIRCLE RADIUS screen.

You can see the coordinates of center point of the arc and the radius of the arc.

RESULT OF CIRCLE RADIUS	
X	+0.000m
Y	+0.000m
Z	+0.000m
RADIUS	+0.000m
ESC	ENT

Press [F5][ENT] to save the coordinates of center point.

RESULT OF CIRCLE RADIUS	
1. PN:	
2. X: + XXXXXXXX.XXX m	
3. Y: + XXXXXXXX.XXX m	
4. Z: + XXXXXXXX.XXX m	
5. PC:	
↑	↓
ACCEPT	

The PN, X, Y, Z and PC are viewed and can be edited.
If all items are OK, press [F5][ACCEPT] to save them.

8.1.4 LINE-ARC INTERSECTION

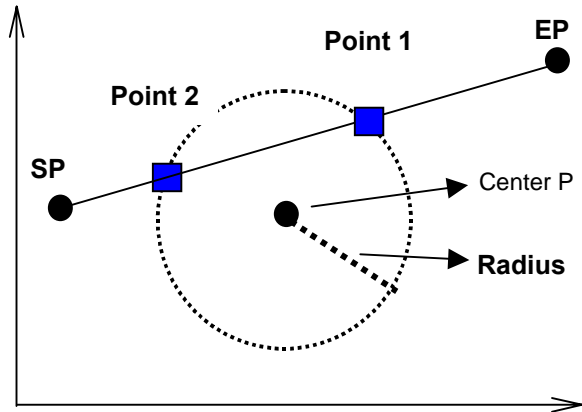

Two intersection points of one line and circle are calculated by this function. The line is drawn by SP and EP. The circle is drawn by center point and radius.
 You can store two possible intersection points.

Input: **Line:** start point and end point
 Arc: center point and radius

Output Two possible intersection points

From the PowerTopoLite screen, press [F2][CALC] to view the CALCULATION screen.

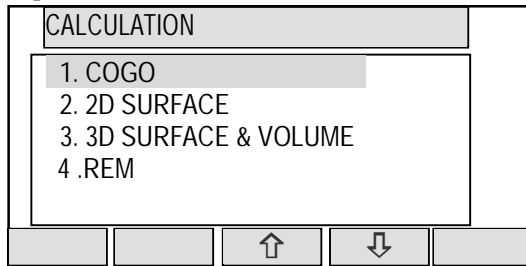

Select 1.COGO and press [ENT] to view the COGO screen.

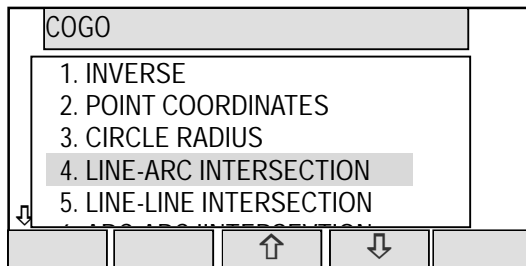

Select the 3. CIRCLE RADIUS and press [ENT] to view LINE-ARC INTERSECTION screen.

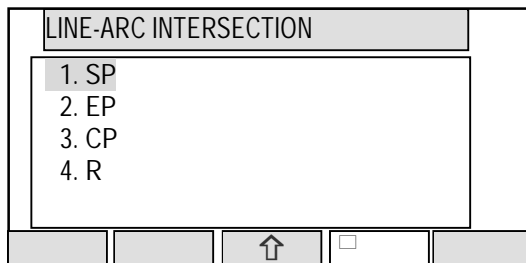

Select 1. SP and press [ENT] to view SP screen.

SP				
1. PN:				
2. X: + 00000000.000 m				
3. Y: + 00000000.000 m				
4. Z: + 00000000.000 m				
5. PC:				
SAVE	LIST	↑	↓	ACCEPT

Input PN (Point Name), X, Y, Z, and PC (Point Code) of SP point or import from the memory of rectangular coordinate as SP by [F2][LIST].

If you finish the input of SP value, press [F5][ACCEPT]. Then you go to EP input screen.

EP				
1. PN:				
2. X: + 00000000.000 m				
3. Y: + 00000000.000 m				
4. Z: + 00000000.000 m				
5. PC:				
SAVE	LIST	↑	↓	ACCEPT

Input EP value like an input of SP. If you finish an input of P2, press [F5][ACCEPT]. Then you go to CP input screen.

CP				
1. PN:				
2. X: + 00000000.000 m				
3. Y: + 00000000.000 m				
4. Z: + 00000000.000 m				
5. PC:				
SAVE	LIST	↑	↓	ACCEPT

If you finish the input of CP value, press [F5][ACCEPT]. Then you go to RADIUS input screen.

RADIUS				
0000.000m				
←	→	↑	↓	CLEAR

If you finish the input of RADIUS, press [ENT]. Then you go to RESULT OF LINE-ARC INTERSECTION screen.

You can see the coordinates of one of intersection point. You can switch to one more intersection point by pressing [F3][ONE MORE].

RESULT OF LINE-ARC INTERSECT.				
X +0.000m				
Y +0.000m				
Z +0.000m				
ESC	ONE MORE			ENT

Press [F5][ENT] to save an intersection point.

RESULT OF COORD. CALCULATE			
1. PN:			
2. X: + XXXXXXXX.XXX m			
3. Y: + XXXXXXXX.XXX m			
4. Z: + XXXXXXXX.XXX m			
5. PC:			
		↑	↓
			ACCEPT

The PN, X, Y, Z and PC are viewed and can be edited.

If all items are OK, press [F5][ACCEPT] to save them. Then you go to another intersection point screen.

RESULT OF COORD. CALCULATE			
1. PN:			
2. X: + XXXXXXXX.XXX m			
3. Y: + XXXXXXXX.XXX m			
4. Z: + XXXXXXXX.XXX m			
5. PC:			
		↑	↓
			ACCEPT

The PN, X, Y, Z and PC are viewed and can be edited.

If all items are OK, press [F5][ACCEPT] to save them.

8.1.5 LINE-LINE INTERSECTION

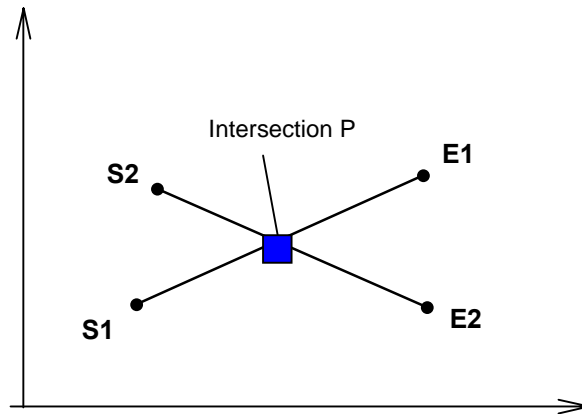

The intersection point of two lines drawn by given two points is calculated by this Function.

Input: First line : Start point and End point
 Second line: Start point and End point

Output: Intersection point between the two lines

From the PowerTopoLite screen, press the [F2][CALC] to view the CALCULATION screen.

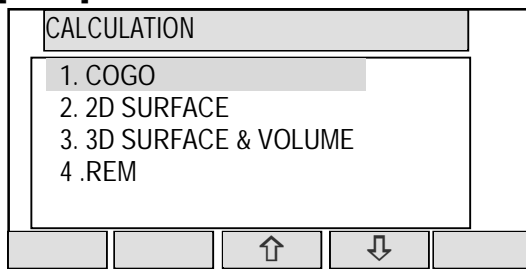

Press 1.COGO to view the COGO screen.

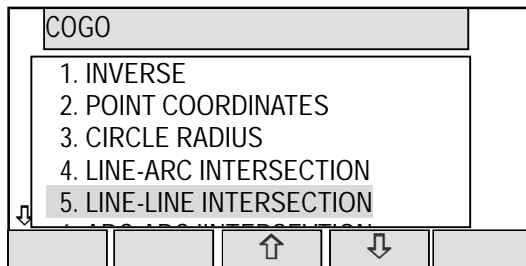

Select 5. LINE-LINE INTERSECTION and press [ENT] to view its screen.

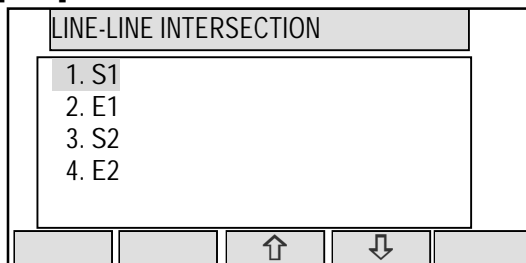

Select 1.S1 and press [ENT] to view its screen.

S1				
1. PN:				
2. X: + 00000000.000 m				
3. Y: + 00000000.000 m				
4. Z: + 00000000.000 m				
5. PC:				
SAVE	LIST	↑	↓	ACCEPT

Press [ENT] to open the PN input screen.

PN				
1. PN: <input type="text"/>				
2. X: + 00000000.000 m				
3. Y: + 00000000.000 m				
4. Z: + 00000000.000 m				
5. PC:				
←	→	BS	CLEAR	TO 123

Input your desired point name by pressing each keys, and press [ENT] to view X screen.

S1				
1. PN:				
2. X: + 00000000.000 m				
3. Y: + 00000000.000 m				
4. Z: + 00000000.000 m				
5. PC:				
SAVE	LIST	↑	↓	ACCEPT

Press [ENT] to open the X coordinate input screen.

X				
1. PN: POI1				
2. X: <input type="text"/>				
3. Y: + 00000000.000 m				
4. Z: + 00000000.000 m				
5. PC:				
←	→			CLEAR

Input your desired value by pressing each keys and press [ENT] to go Y coordinate.

S1				
1. PN:				
2. X: + 00000000.000 m				
3. Y: <input type="text"/>				
4. Z: + 00000000.000 m				
5. PC:				
SAVE	LIST	↑	↓	ACCEPT

Press [ENT] to open the Y coordinate input screen.

Y				
1. PN: POT1				
2. X: + 00000000.000 m				
3. Y: <input type="text"/>				
4. Z: + 00000000.000 m				
5. PC:				
←	→			CLEAR

In the same manner, input your desired value by pressing each keys and press [ENT] to open the Z coordinate input screen.

Z				
1. PN: POT1				
2. X: + 00000000.000 m				
3. Y: + 00000000.000 m				
4. Z: + 00000000.000 m				
5. PC:				
←	→			CLEAR

Input your desired value by pressing each keys and press [ENT] to open the PC, Point Code, input screen.

PC				
1. PN: POT1				
2. X: + 00000000.000 m				
3. Y: + 00000000.000 m				
4. Z: + 00000000.000 m				
5. PC: <input type="text"/>				
←	→			CLEAR

Input your desired PC by pressing each keys, and press [ENT] to view EI screen.

In the same manner, the values of E1, S2 and E2 are all inputted.

E1				
1. PN:				
2. X: + 00000000.000 m				
3. Y: + 00000000.000 m				
4. Z: + 00000000.000 m				
5. PC:				
SAVE	LIST	↑	↓	ACCEPT

The intersection Coordinates are displayed.

RESULT OF LINE-LINE INTERSECT.				
X	+0.000m			
Y	+0.000m			
Z	+0.000m			
ESC				ENT

Press [ENT] to view the following screen.

RESULT OF COORD. CALCULATE				
1. PN:				
2. X: + XXXXXXXX.XXX m				
3. Y: + XXXXXXXX.XXX m				
4. Z: + XXXXXXXX.XXX m				
5. PC:				
SAVE	LIST	↑	↓	ACCEPT

The PN, X, Y, Z and PC are viewed and can be edited.
If all items are OK, press [F1][SAVE] or [F5][ACCEPT] to save them.

8.1.6 ARC-ARC INTERSECTION

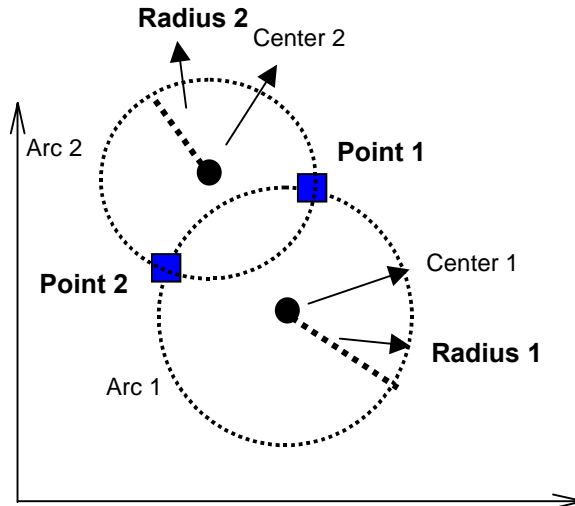

Two intersection points of two arcs drawn by each center point and radius are calculated. You can store two possible intersection points.

Input: Arc 1: center point and radius
 Arc 2: center point and radius

Output: Two possible intersection points

From the PowerTopoLite screen, press [F2][CALC] to view the CALCULATION screen.

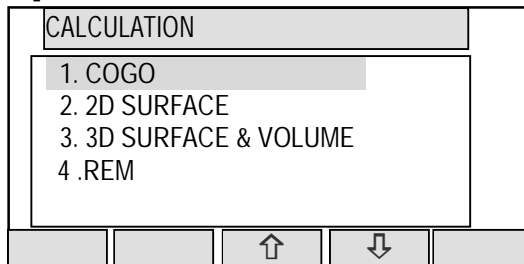

Select 1.COGO and press [ENT] to view the COGO screen.

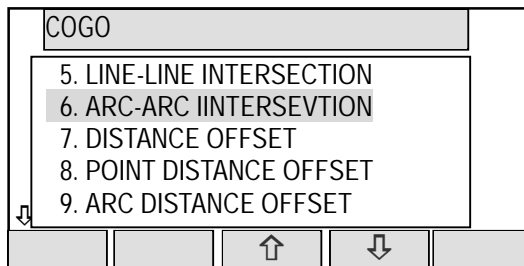

Select the 6. ARC-ARC INTERSECTION and press [ENT] to view ARC-ARC INTERSECTION screen.

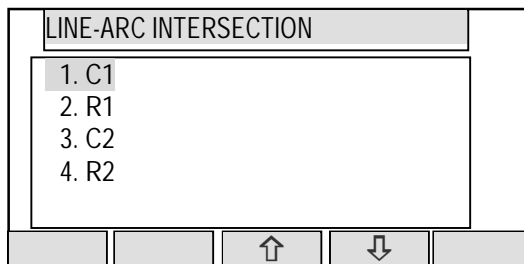

Select 1. C1 and press [ENT] to view C1 screen.

C1	
1. PN:	
2. X: + 00000000.000 m	
3. Y: + 00000000.000 m	
4. Z: + 00000000.000 m	
5. PC:	
SAVE	LIST
↑	↓
ACCEPT	

C1 (Center 1) point is center point of Arc 1.
 Input PN (Point Name), X, Y, Z, and PC (Point Code) of C1 point or import from the memory of rectangular coordinate as C1 by [F2][LIST].

If you finish the input of C1 value, press [F5][ACCEPT]. Then you go to R1 input screen.

R1	
000.000m	
←	→
CLEAR	

Input the radius of Arc 1 as R1 value. If you finish the input of R1, press [F5][ACCEPT]. Then you go to C2 input screen.

C2	
1. PN:	
2. X: + 00000000.000 m	
3. Y: + 00000000.000 m	
4. Z: + 00000000.000 m	
5. PC:	
SAVE	LIST
↑	↓
ACCEPT	

C2 (Center 2) point is center point of Arc 2.
 Input PN (Point Name), X, Y, Z, and PC (Point Code) of C2 point or import from the memory of rectangular coordinate as C2 by [F2][LIST].

If you finish the input of C2 value, press [F5][ACCEPT]. Then you go to R2 input screen.

R2	
000.000m	
←	→
CLEAR	

Input the radius of Arc 2 as R2 value. If you finish the input of R2, press [ENT]. Then you go to RESULT OF LINE-ARC INTERSECTION screen.

You can see the coordinates of one of intersection point. You can switch to one more intersection point by pressing [F3][ONE MORE].

RESULT OF ARC-ARC INTERSECT.	
X	+0.000m
Y	+0.000m
Z	+0.000m
ESC	ONE MORE
ENT	

Press [F5][ENT] to save one of intersection point.

RESULT OF COORD. CALCULATE			
1. PN:			
2. X: + XXXXXXXX.XXX m			
3. Y: + XXXXXXXX.XXX m			
4. Z: + XXXXXXXX.XXX m			
5. PC:			
		↑	↓
			ACCEPT

The PN, X, Y, Z and PC are viewed and can be edited.

If all items are OK, press [F5][ACCEPT] to save them. Then you go to another intersection point screen.

RESULT OF COORD. CALCULATE			
1. PN:			
2. X: + XXXXXXXX.XXX m			
3. Y: + XXXXXXXX.XXX m			
4. Z: + XXXXXXXX.XXX m			
5. PC:			
		↑	↓
			ACCEPT

The PN, X, Y, Z and PC are viewed and can be edited.

If all items are OK, press [F5][ACCEPT] to save them.

8.1.7 DISTANCE OFFSET

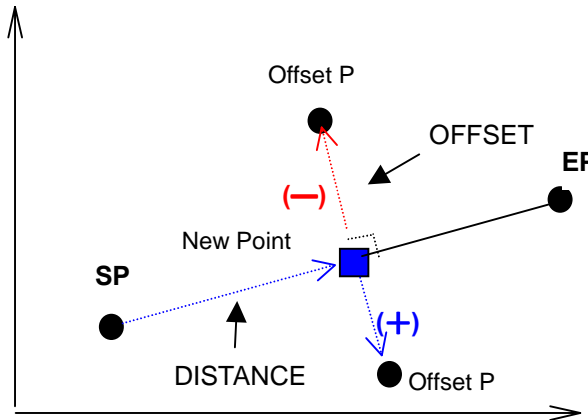

Offset distance of new point to the line and distance of start point to new point are displayed. Also new Point on the line is calculated by point of start, end, and offset. You can store the new point.

Input: line : start point (SP) and end point (EP)
offset point (OP)

Output: new point
offset of new point from the line
(moving in the direction from start point to end point, right is positive, left is negative)
distance of new point from start point

From the PowerTopoLite screen, press [F2][CALC] to view the CALCULATION screen.

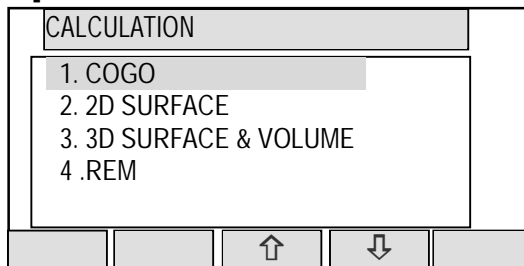

Select 1.COGO and press [ENT] to view the COGO screen.

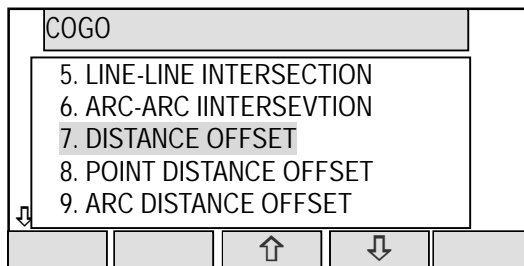

Select the 7. DISTANCE OFFSET and press [ENT] to view DISTANCE OFFSET screen.

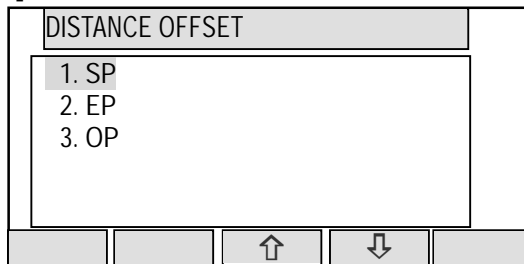

Select 1. SP and press [ENT] to view SP screen.

SP				
1. PN:				
2. X: + 00000000.000 m				
3. Y: + 00000000.000 m				
4. Z: + 00000000.000 m				
5. PC:				
SAVE	LIST	↑	↓	ACCEPT

Input PN (Point Name), X, Y, Z, and PC (Point Code) of SP point or import from the memory of rectangular coordinate as SP by [F2][LIST].

If you finish the input of SP value, press [F5][ACCEPT]. Then you go to EP input screen.

EP				
1. PN:				
2. X: + 00000000.000 m				
3. Y: + 00000000.000 m				
4. Z: + 00000000.000 m				
5. PC:				
SAVE	LIST	↑	↓	ACCEPT

Input EP data like input of SP. If you finish the input of EP, press [F5][ACCEPT]. Then you go to OP input screen.

OP				
1. PN:				
2. X: + 00000000.000 m				
3. Y: + 00000000.000 m				
4. Z: + 00000000.000 m				
5. PC:				
SAVE	LIST	↑	↓	ACCEPT

If you finish the input of OP, press [F5][ACCEPT]. Then you go to RESULT OF DISTANCE OFFSET screen.

You can see the coordinates of new point on the line, offset distance of new point to the line and distance of new point to start point.

RESULT OF DISTANCE OFFSET				
X	+0.000m			
Y	+0.000m			
Z	+0.000m			
DISTANCE	+0.000m			
OFFSET	+0.000m			
ESC				ENT

Press [F5][ENT] to save the coordinates of new point.

RESULT OF COORD. CALCULATE				
1. PN:				
2. X: + XXXXXXXX.XXX m				
3. Y: + XXXXXXXX.XXX m				
4. Z: + XXXXXXXX.XXX m				
5. PC:				
		↑	↓	ACCEPT

The PN, X, Y, Z and PC are viewed and can be edited.
If all items are OK, press [F5][ACCEPT] to save them.

8.1.8 POINT DISTANCE OFFSET

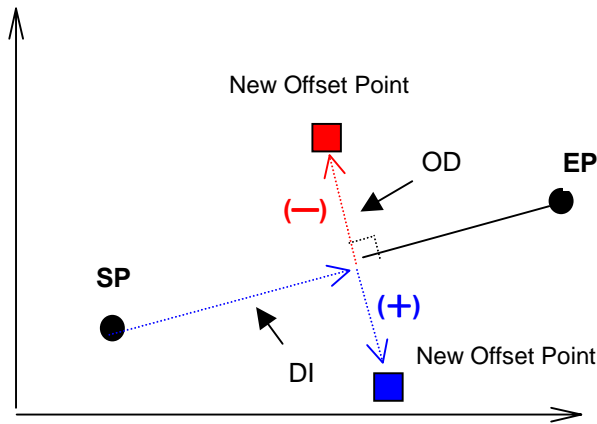

New offset point is calculated by inputting distance from start point and offset from line.

Input: line : start point and end point
 distance from start point (DI)
 offset from the line (OD) (moving in the direction from start point to end point, right is positive, left is negative)

Output: new point

From the PowerTopoLite screen, press [F2][CALC] to view the CALCULATION screen.

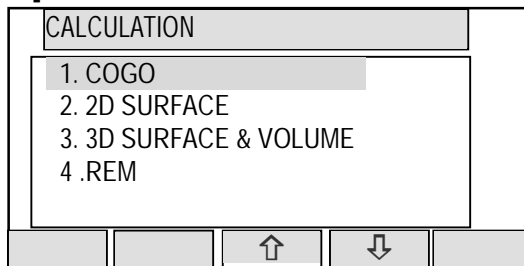

Select 1.COGO and press [ENT] to view the COGO screen.

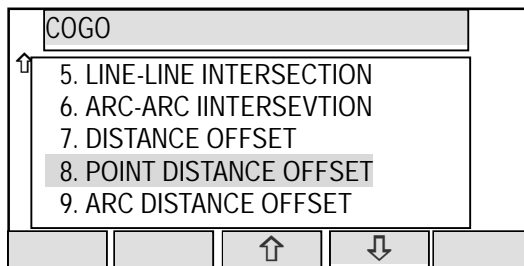

Select the 8. POINT DISTANCE OFFSET and press [ENT] to view POINT DISTANCE OFFSET screen.

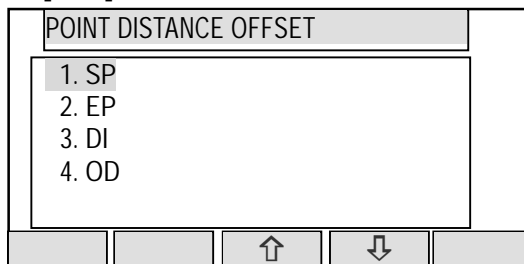

Select 1. SP and press [ENT] to view SP screen.

SP				
1. PN:				
2. X: + 00000000.000 m				
3. Y: + 00000000.000 m				
4. Z: + 00000000.000 m				
5. PC:				
SAVE	LIST	↑	↓	ACCEPT

Input PN (Point Name), X, Y, Z, and PC (Point Code) of SP point or import from the memory of rectangular coordinate as SP by [F2][LIST].

If you finish the input of SP value, press [F5][ACCEPT]. Then you go to EP input screen.

EP				
1. PN:				
2. X: + 00000000.000 m				
3. Y: + 00000000.000 m				
4. Z: + 00000000.000 m				
5. PC:				
SAVE	LIST	↑	↓	ACCEPT

Input EP data like input of SP. If you finish the input of EP, press [F5][ACCEPT]. Then you go to DISTANCE input screen.

DISTANCE				
0000.000m				
←	→	↑	↓	CLEAR

Input DI (Distance from SP to point on the line). If you finish the input of DI, press [F5][ACCEPT]. Then you go to OFFSET input screen.

OFFSET				
0000.000m				
←	→	↑	↓	CLEAR

Input OD (Offset distance from the line to offset point). If you finish the input of OD, press [F5][ACCEPT]. Then you go to RESULT OF POINT DISTANCE OFFSET screen. You can see the coordinates of offset point from the line.

RESULT OF POINT DISTANCE OFFSET			
X	+0.000m		
Y	+0.000m		
Z	+0.000m		
ESC			ENT

Press [F5][ENT] to save the coordinates of offset point.

RESULT OF COORD. CALCULATE			
1. PN:			
2. X: + XXXXXXXX.XXX m			
3. Y: + XXXXXXXX.XXX m			
4. Z: + XXXXXXXX.XXX m			
5. PC:			
		↑	↓
			ACCEPT

The PN, X, Y, Z and PC are viewed and can be edited.
If all items are OK, press [F5][ACCEPT] to save them.

8.1.9 ARC DISTANCE OFFSET

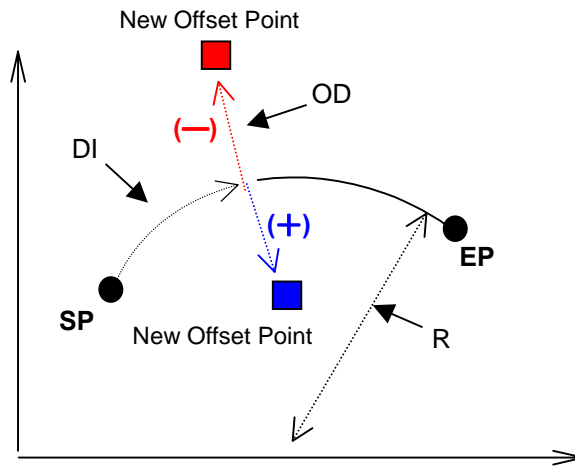

Offset point from the arc is calculated.

Input: arc : start point, end point and radius (R)
 distance along arc from start point (DI)
 offset from the arc (OD) (moving in the direction from start point to end point, right is positive, left is negative)

Note: From start point to end point must be **CLOCKWISE**. If you calculate by arc of **COUNTERCLOCKWISE**, change SP for EP and calculate changed DI manually.

Output: new offset point

From the PowerTopoLite screen, press [F2][CALC] to view the **CALCULATION** screen.

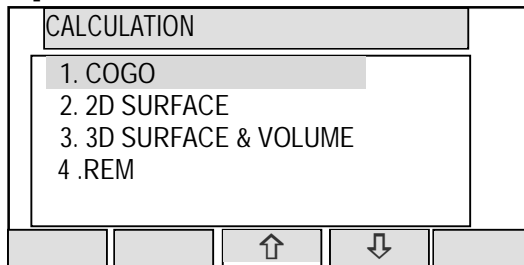

Select 1.COGO and press [ENT] to view the **COGO** screen.

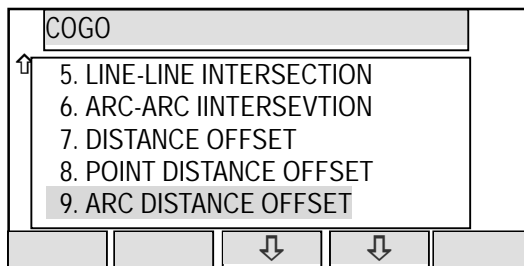

Select the 9. ARC DISTANCE OFFSET and press [ENT] to view **ARC DISTANCE OFFSET** screen.

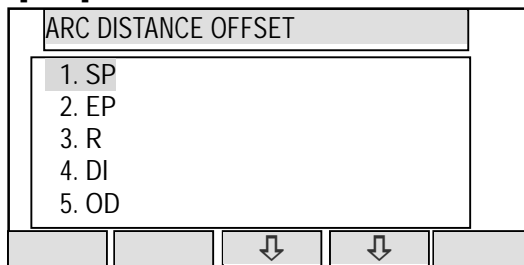

Select 1. SP and press [ENT] to view SP screen.

SP				
1. PN:				
2. X: + 00000000.000 m				
3. Y: + 00000000.000 m				
4. Z: + 00000000.000 m				
5. PC:				
SAVE	LIST	↓	↓	ACCEPT

Input PN (Point Name), X, Y, Z, and PC (Point Code) of SP point or import from the memory of rectangular coordinate as SP by [F2][LIST].

If you finish the input of SP value, press [F5][ACCEPT]. Then you go to EP input screen.

EP				
1. PN:				
2. X: + 00000000.000 m				
3. Y: + 00000000.000 m				
4. Z: + 00000000.000 m				
5. PC:				
SAVE	LIST	↓	↓	ACCEPT

Input EP data like an input of SP. If you finish input of EP, press [F5][ACCEPT]. Then you go to RADIUS input screen.

RADIUS				
0000.000m				
←	→			CLEAR

Input RADIUS (Radius of circle). If you finish the input of RADIUS, press [ENT]. Then you go to DISTANCE input screen.

DISTANCE				
0000.000m				
←	→			CLEAR

Input DI STANCE (Distance from SP to point on the arc). If you finish the input of DISTANCE, press [ENT]. Then you go to OFFSET input screen.

OFFSET				
0000.000m				
←	→			CLEAR

Input OFFSET (Offset distance from the arc to offset point). If you finish the input of OFFSET, press [ENT]. Then you go to RESULT OF ARC DISTANCE OFFSET screen. You can see the coordinates of offset point from the arc.

RESULT OF ARC DISTANCE OFFSET	
X	+0.000m
Y	+0.000m
Z	+0.000m

ESC				ENT
-----	--	--	--	-----

Press [F5][ENT] to save the coordinates of offset point.

RESULT OF COORD. CALCULATE	
1. PN:	
2. X: +	XXXXXXXXX.XXX m
3. Y: +	XXXXXXXXX.XXX m
4. Z: +	XXXXXXXXX.XXX m
5. PC:	

		↓	↓	ACCEPT
--	--	---	---	--------

The PN, X, Y, Z and PC are viewed and can be edited. If all items are OK, press [F5][ACCEPT] to save them.

8.2 2D SURFACE

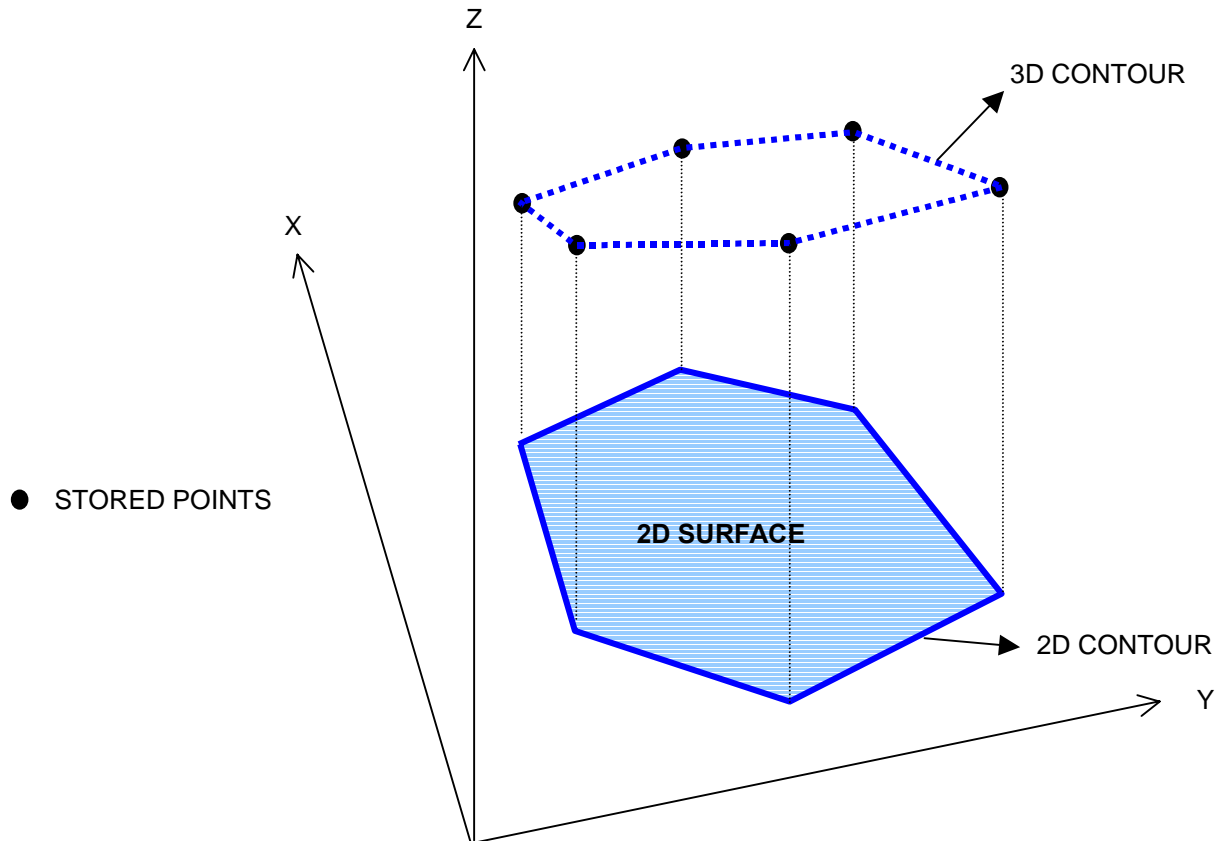

This function calculates the 2D and 3D contour of a polygon and the 2D surface of the area defined by the polygon.

You define the polygon by selecting points and PowerTopoLite then calculates contour and 2D surface.

Note: The polygon is defined by the point you select. Therefore, the order in which you enter the point is important. If you select points by [ALL] or [FROM][TO], the polygon is defined according to the order of the memory address. If you select points one by one by [ENT], the polygon is defined according to the order of your selection.

Note: You have to select points in such a way that the line segments that define the polygon do not intersect.

Note: Selected points should be less than 1500 points.

From the PowerTopoLite screen, press [F2][CALC] to view the CALCULATION screen.

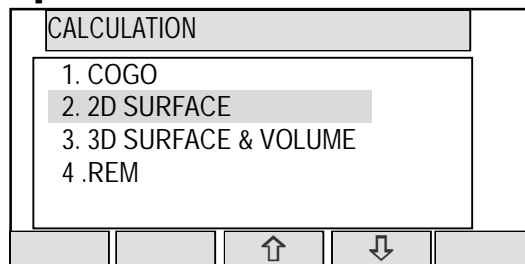

Select 2. 2D SURFACE and press [ENT] to view POINT SELECTION FROM THE LIST screen.

POINT SELECTION FROM THE LIST	
↑	10 / 15
PN:POT1	
X*	+ 00000100.000 m
Y*	- 00000200.000 m
Z*	+ 00000010.000 m
ACCEPT	ALL
↑	↓
PAGE	

If you press [F5][PAGE], you can see another screen.

POINT SELECTION FROM THE LIST	
↑	10 / 15
PN:POT1	
X*	+ 00000100.000 m
Y*	- 00000200.000 m
Z*	+ 00000010.000 m
ORDER	FIND PN
FROM	TO
PAGE	

You select points, which defines the polygon in order at this screen.

How to select points of polygon

[ENT] key

Move to selection point by [F3] and [F4] arrow keys and press [ENT] to select it one by one and each indication is reversed as follows. Reverse display shows that it was selected. If you cancel the selection of the point, press [ENT] again. And you can cancel the selection point one by one after pressing [ALL].

POINT SELECTION FROM THE LIST	
↑	10 / 15
PN:POT1	
X*	+ 00000100.000 m
Y*	- 00000200.000 m
Z*	+ 00000010.000 m
ACCEPT	ALL
↑	↓
PAGE	

[F2][ALL] key

Press [F2][ALL] to select all stored points of current JOB. The order of points is according to the arrangement of the memory. if you press [F2][ALL] again, the selection of all points are canceled. You can cancel the selection point by [ENT] one by one after pressing [ALL]. If you press [F2][ALL] after you already selected some points, the selection of each points are reversed.

[F3][FROM] key and [F4][TO] key

You can define the range of polygonal points from all points of current JOB by [F3][FROM] and [F4][TO] as follows.

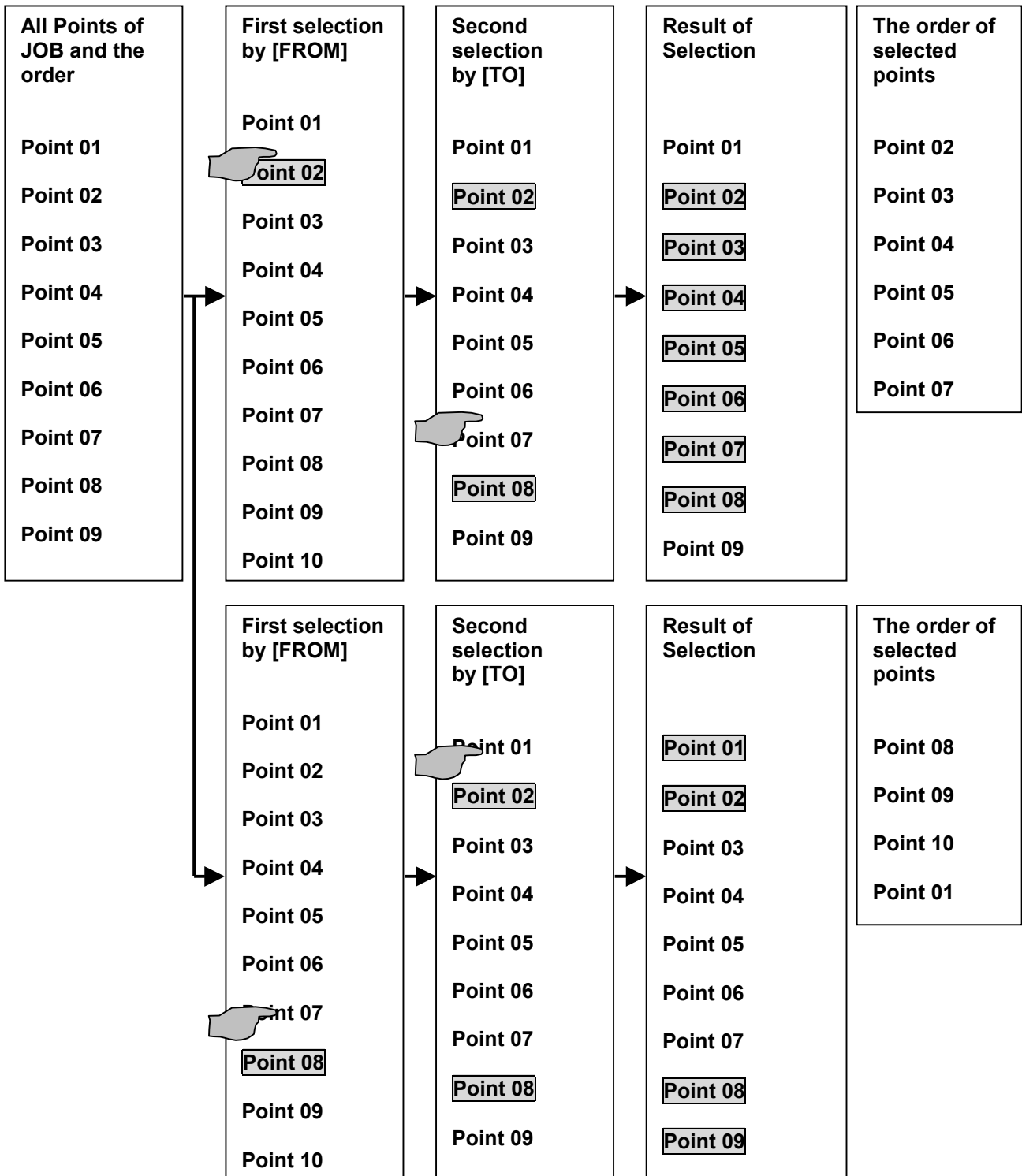

Note: [F1][ORDER] key
 Press [F1][ORDER] to confirm order of selected points after you finished the selection.
 If you finish point selection of a polygon, press [F1][ACCEPT] to calculate. The result of calculation is displayed as follows.

RESULT OF 2D SURFACE	
CONTOUR	
2D:	X.XXXm
3D:	X.XXXm
2D SURF	X.XXXm ²
ESC	ENT

Press [ENT] or [ESC] to return to POINT SELECTION FROM THE LIST screen. You change a selection, and you can calculate it again.

8.3 3D SURFACE AND VOLUME

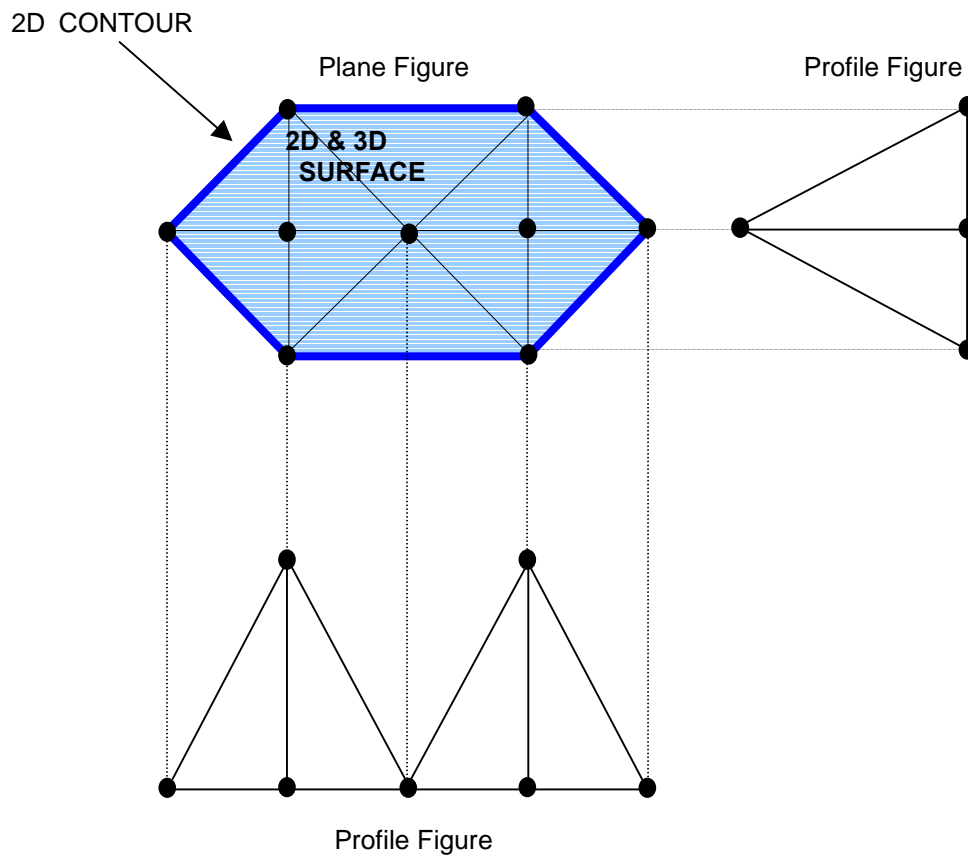

This function calculates the center, the 2D and 3D surface and positive, negative and total volume.

First, you select the points that are used for the volume calculation. The order in which you select the points is not important. Please refer 2D SURFACE chapter about selection way. PowerTopoLite generates a mesh (triangulation) of the points automatically and calculates the result based on the mesh.

The contour of the points will always be convex. A polygon is generated so that an area may become the biggest. It is like a rope, which is laid around the points, and then tighten.

You have to give the reference height, which is used for volume calculation: the part of the volume that is situated below the reference height is called negative volume and the part above the reference height is called positive volume.

Note: Relations between each volume and reference height are as follows.

Note: Selected points should be less than 350 points.

In 3D Volume, the case that inputted reference height is lower than a solid

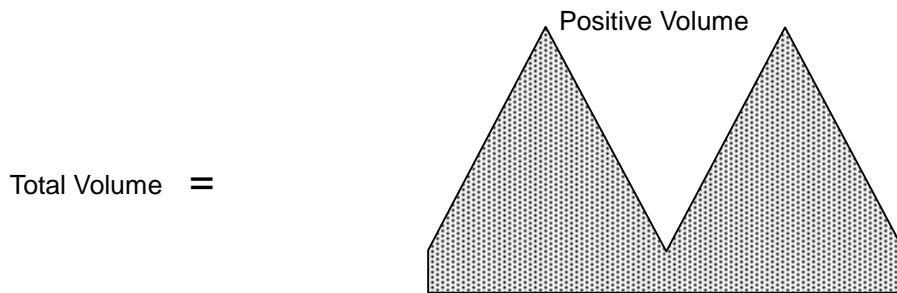
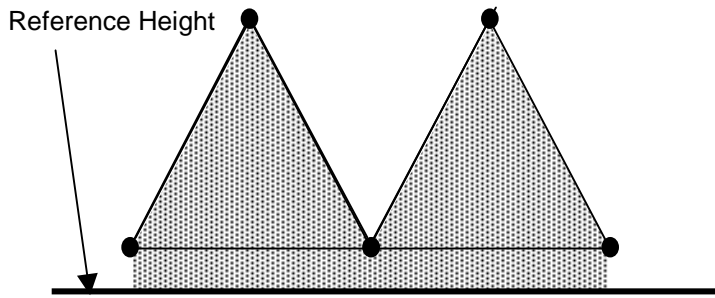

In 3D Volume, the case that inputted reference height is between a solid

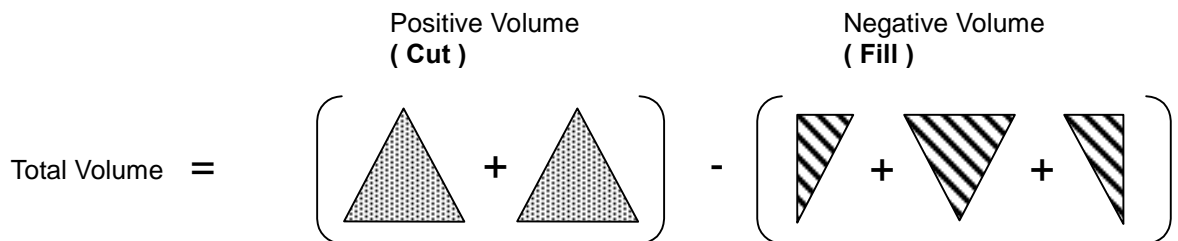
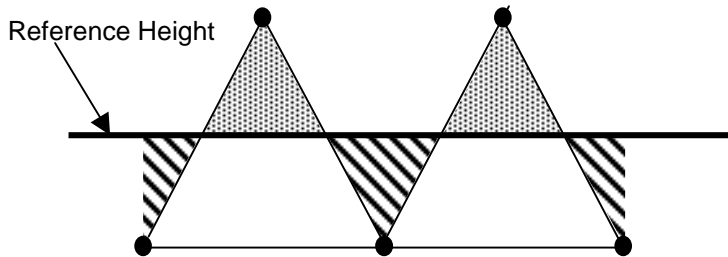

In 3D Volume, the case that inputted reference height is higher than a solid

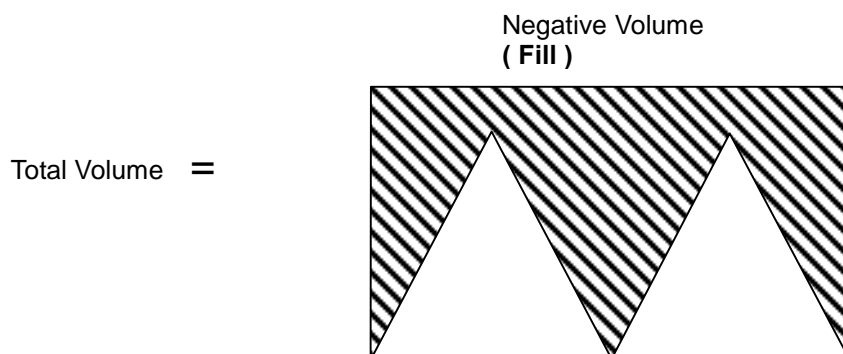
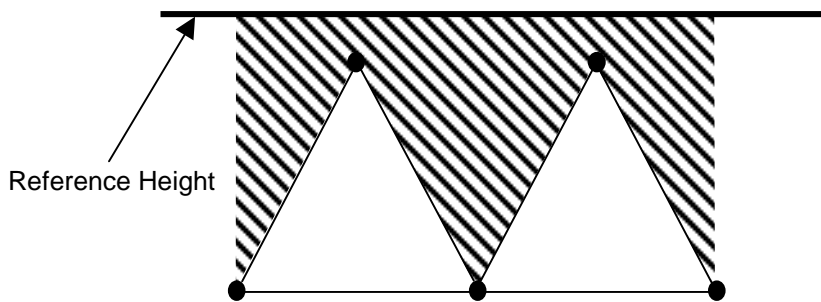

From the PowerTopoLite screen, press [F2][CALC] to view the CALCULATION screen.

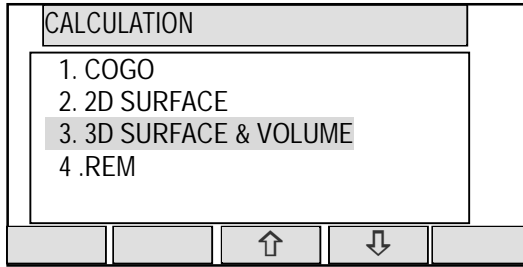

Select 3. 3D SURFACE & VOLUME and press [ENT] to view POINT SELECTION FROM THE LIST screen.

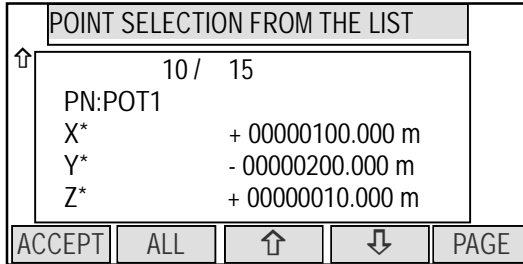

If you press [F5][PAGE], you can see another screen.

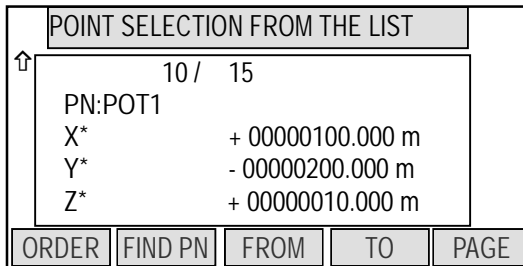

You select points, which composes the polygon in order at this screen.

If you finish point selection of a polygon, press [F1][ACCEPT] to go to RH screen.
(RH stand for the Reference Height.)

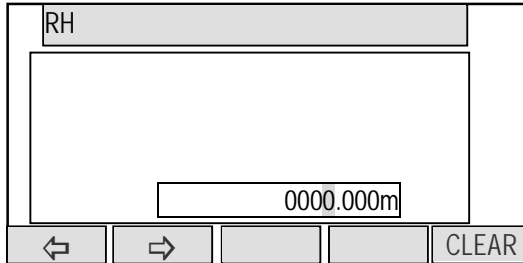

Input reference height. If you finish it, press [ENT] to calculate. The result of calculates is displayed as follows.

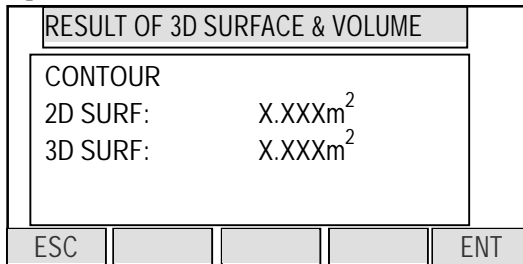

Press [ENT] to go to next screen as follows.

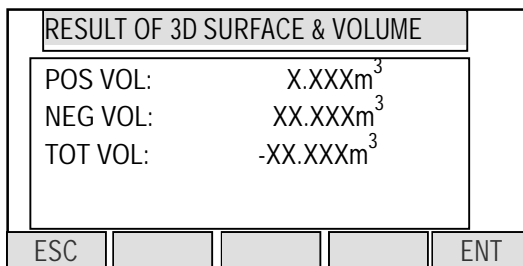

Press [ESC] to return to POINT SELECTION FROM THE LIST screen. You change a selection, and you can calculate it again.

8.3 REM

General pictures of measurement

With REM measurement, a prism (Reference point) is set approximately directly below the place to be measured, and by measuring the prism, the height to the target object can be measured. This makes it easy to determine the heights of electric power lines, bridge suspension cables, and other large items used in construction.

General pictures

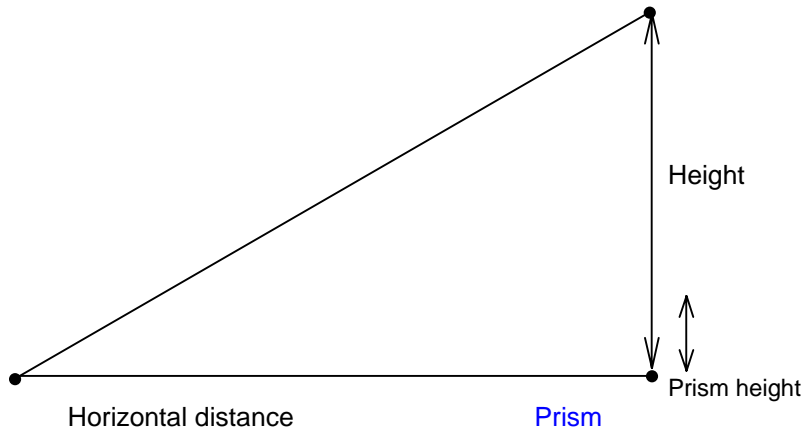

From the PowerTopoLite screen, press [F2][CALC] to view the CALCULATION screen.

CALCULATION	
1. COGO	
2. 2D SURFACE	
3. 3D SURFACE & VOLUME	
4. REM	
↑	↓

Select 4.REM and press [ENT] to view MEASURE screen.

REM	25C	N	0
PH	1.200	m	
H.angle	xxx°	xx'	xx"
V.angle	xx°	xx'	xx"
H.dst			
MEAS	SAVE	ME/SAVE	PAGE

Please press [ENT] after measuring distance.

REM	25C	N	0
PH	1.200	m	
H.angle	xxx°	xx'	xx"
V.angle	xx°	xx'	xx"
REM	xxxxxx	m	



9 VPM

Virtual Plane Measurement

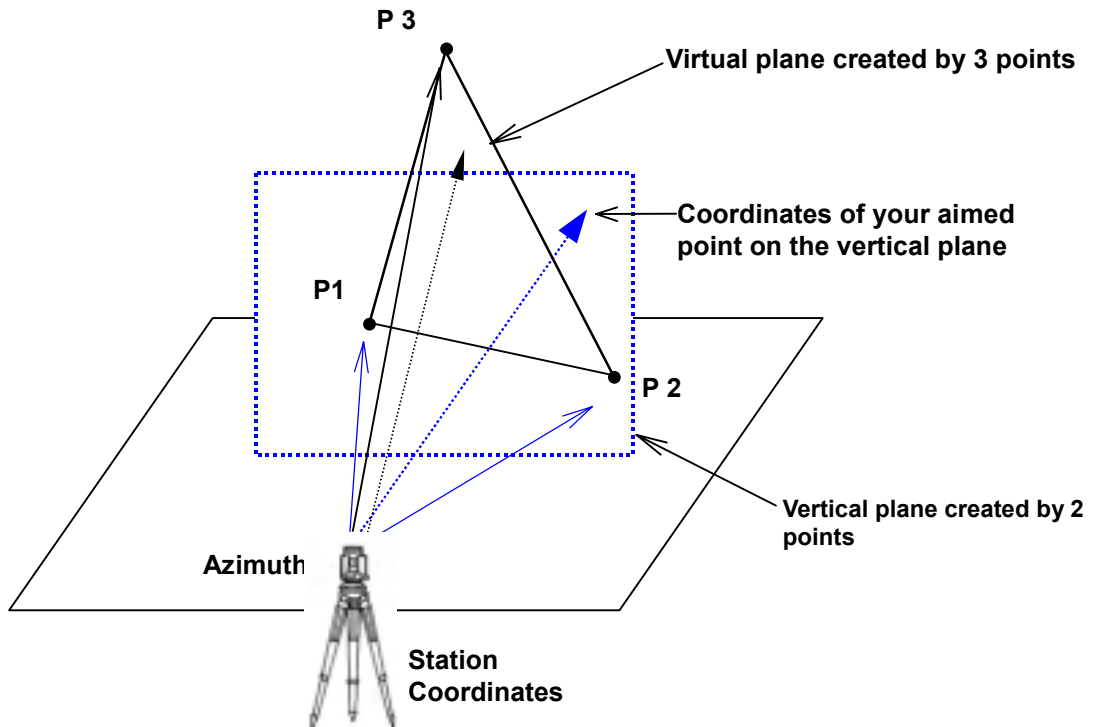

The Virtual plane includes the Vertical plane.

With VPM measurement, the Coordinates on the vertical plane and virtual plane can be obtained by entering the “Station Coordinates and Azimuth” and by measuring point 1, point 2 and point 3. Two points make a vertical plane and three points make a virtual plane. You can measure the point Coordinates of this virtual plane by aiming at your desired points.

Press the [F3][VPM] of the PowerTopoLite screen to view the STATION POINT SETUP screen of the VPM function.

STATION POINT SETUP					
1. PN:					
2. X: + 00000000.000 m					
3. Y: + 00000000.000 m					
4. Z: + 00000000.000 m					
5. IH: 0000.000 m					
↓	SAVE	LIST	↑	↓	ACCEPT

- [LIST] key

All stored points can be displayed as follows by pressing [F2][LIST].

Press the [F2][LIST] to view POINT SELECTION FROM THE LIST screen. You can enter Coordinates data by applying the List data.

POINT SELECTION FROM THE LIST					
4 / 15					
PN x XXXXX					
X x+ 000000XX.000 m					
Y x+ 000000XX.000 m					
Z x + 000000XX.000 m					
↓	DELETE	FIND PN	↑	↓	

Press [ENT] to open the input window of PN, X, Y, Z and IH value.
 Input each Character or value and press the ENT key to view the **STATION POINT H. ANGLE SETUP** screen.

STATION POINT H. ANGLE SETUP				
H. angle 123° 45' 25"				
	INPUT	0 SET	HOLD	BSP

Input the H. angle by pressing [F2][INPUT], [F3][0SET] and [F4] [HOLD] or **Backsight Coordinates** by pressing [F5][BSP].

Press [ENT] to open the input window when using [F5][BSP].

Pressing [F2][INPUT]

H ANGLE				
H. angle XXX° XX' XX"				
←	→	↑	↓	CLEAR

Pressing [F5][BSP]

BSP SETUP				
1. PN:				
2. X: + 00000000.000 m				
3. Y: + 00000000.000 m				
4. Z: + 00000000.000 m				
5. PC:				
SAVE	LIST	↑	↓	ACCEPT

Aim at the reference point, and press [ENT] to view the **MEASURE** screen.

MEASURE				
1 3				
PH 0.000 m				
X				
Y				
Z				
MEAS	SAVE	ME/SAVE	EDIT	PAGE

Aim at point 1 and press [F1][MEAS] . **Measured Coordinates are displayed.**

MEASURE				
1 3				
PH 0.000 m				
X +X.XXX m				
Y +X.XXX m				
Z +X.XXX m				
MEAS	SAVE	ME/SAVE	EDIT	PAGE

Press [ENT] to view the same **MEASURE** screen.

MEASURE				
2 3				
PH 0.000 m				
X				
Y				
Z				
MEAS	SAVE	ME/SAVE	EDIT	PAGE

In the same manner, aim at point 2 and press [F1][MEAS]. Measured Coordinates are displayed.

COORD. ON THE VIRTUAL PLANE	
2 3	
PH	0.000 m
X	+X.XXX m
Y	+X.XXX m
Z	+X.XXX m
MEAS	SAVE POINT1 EDIT PAGE

Press [ENT] to view the COORD. ON THE VIRTUAL PLANE screen.

Aim at your desired point and press [ENT]. The Coordinates, which you aim at, are displayed.

COORD. ON THE VIRTUAL PLANE	
PN 3	
PH	0.000 m
X	+X.XXX m
Y	+X.XXX m
Z	+X.XXX m
POINT3	SAVE POINT1 EDIT

Press the [F1][POINT3] to view the MEASURE screen.

MEASURE	
3 3	
PH	0.000 m
X	+X.XXX m
Y	+X.XXX m
Z	+X.XXX m
MEAS	SAVE ME/SAVE EDIT PAGE

Aim at point 3 and press [F1][MEAS] . Measured Coordinates are displayed.

COORD. ON THE VIRTUAL PLANE	
2 3	
PH	0.000 m
X	+X.XXX m
Y	+X.XXX m
Z	+X.XXX m
MEAS	SAVE POINT1 EDIT PAGE

Press [ENT] to view the COORD. ON THE VIRTUAL PLANE screen

Aim at your desired point and press [ENT]. The Coordinates, which you aim at, are displayed.

COORD. ON THE VIRTUAL PLANE	
PN 3	
PH	0.000 m
X	+X.XXX m
Y	+X.XXX m
Z	+X.XXX m
POINT3	SAVE POINT 1 EDIT

Pressing [F4][EDIT] can edit the point name and prism height.



10 RDM

Remote Distance Measurement

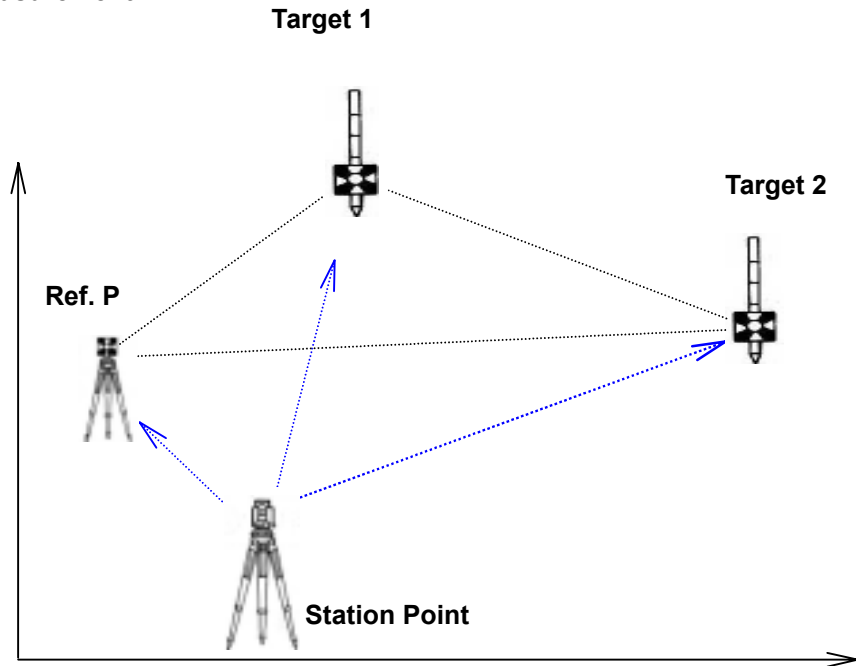

With RDM measurement, the Horizontal, Vertical and Slope distance and % of Slope between the Reference point and the Target point are measured. The distance between Target 1 and Target 2 are also measured. Any Target point can be changed to the new Reference point.

Press the [F4][VPM] of the PowerTopoLite screen to view the REF. POINT screen of the RDM function.

REF. POINT	
PH	1.200 m
H.angle	xxx° xx' xx"
V.angle	xx° xx' xx"
H.dst	
MEAS	TARGET
	EDIT DISP

10.1 PH input

Press [F4][EDIT] to input the PH, Reference point height.

REF. POINT	
0000.000 m	
←	→
	CLEAR

10.2 Reference point - Target distance

Aim at the Reference point and press [F1][MEAS] to measure the Reference point. It turns to TARGET POINT screen automatically.

TARGET POINT	
PH	1.200 m
H.angle	xxx° xx' xx"
V.angle	xx° xx' xx"
H.dst	
MEAS	TARGET
	EDIT DISP

Aim at the Target 1 and press [F1][MEAS] to measure a distance. The distance between Reference point and Target point 1 is displayed.

RESULT OF RDM REF.-TARGET			
H.dst	+x.xxx	m	
V.dst	+x.xxx	m	
S.dst	+x.xxx	m	
%grade	+x.xxx	%	
MEAS		DATA	DISP

V.dst. and % grade are displayed by minus mark when the Target point height is lower position.

Press the [F3][DATA] to view the TARGET POINT screen.

TARGET POINT			
PH	1.200	m	
H.angle	xxx°	xx'	xx"
V.angle	xx°	xx'	xx"
H.dst			
MEAS	TARGET	EDIT	DISP

10.3 Target- Target distance

Aim at the Target 2 and press [F1][MEAS] to measure a distance. The distance between Reference point and Target point 2 is displayed.

RESULT OF RDM REF.-TARGET			
H.dst	+x.xxx	m	
V.dst	+x.xxx	m	
S.dst	+x.xxx	m	
%grade	+x.xxx	%	
MEAS		DATA	DISP

Press [F5][DISP] to display the Target- Target distance.

RESULT OF RDM TARGET-TARGET			
H.dst	+x.xxx	m	
V.dst	+x.xxx	m	
S.dst	+x.xxx	m	
%grade	+x.xxx	%	
MEAS		DATA	DISP

10.4 New Reference point selection

Press [ENT] to view the REF. POINT SELECTION screen. New Ref. point can be selected.

REF. POINT SELECTION			
Use current Target as Ref. ?			
Press [ENT] to confirm.			
Press [ESC] to abort.			
ESC			ENT

Press the [F5][ENT] to view the TARGET POINT screen. Reference point is changed.
Input the new PH and repeat the same procedure as the above.

TARGET POINT				
PH	1.200	m		
H.angle	xxx°	xx'	xx"	
V.angle	xx°	xx'	xx"	
H.dst				
MEAS	TARGET		EDIT	DISP

11. Traverse



This function is for fixed, closed and open traverse calculations.

You can measure not only the corner points but also the sideshot points at the same time. When the traverse is closed, the closing errors of coordinates are calculated and the corner points can be adjusted. In addition, the sideshot points from the corner point based on the adjusted each corner point's coordinates are calculated.

One point of the traverse data uses the memory size of two or three coordinates data. Therefore, please confirm the remaining memory. The calculation type is the compass rule.

The traverse function can store the polar coordinates data and the rectangular coordinates data. And it can send the polar data by DC1 or AUX format and rectangular data by DC1 or CSV format respectively.

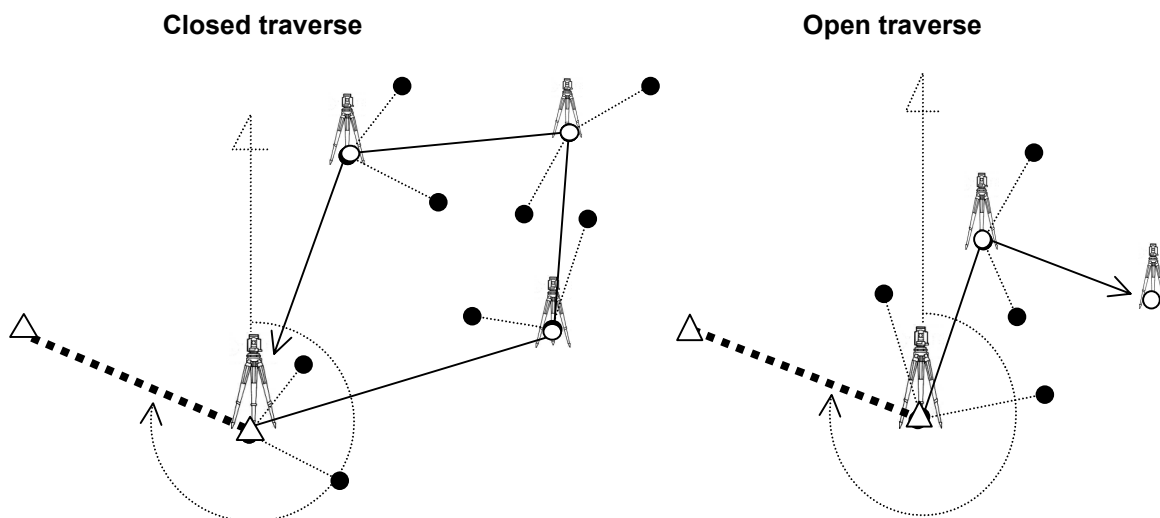
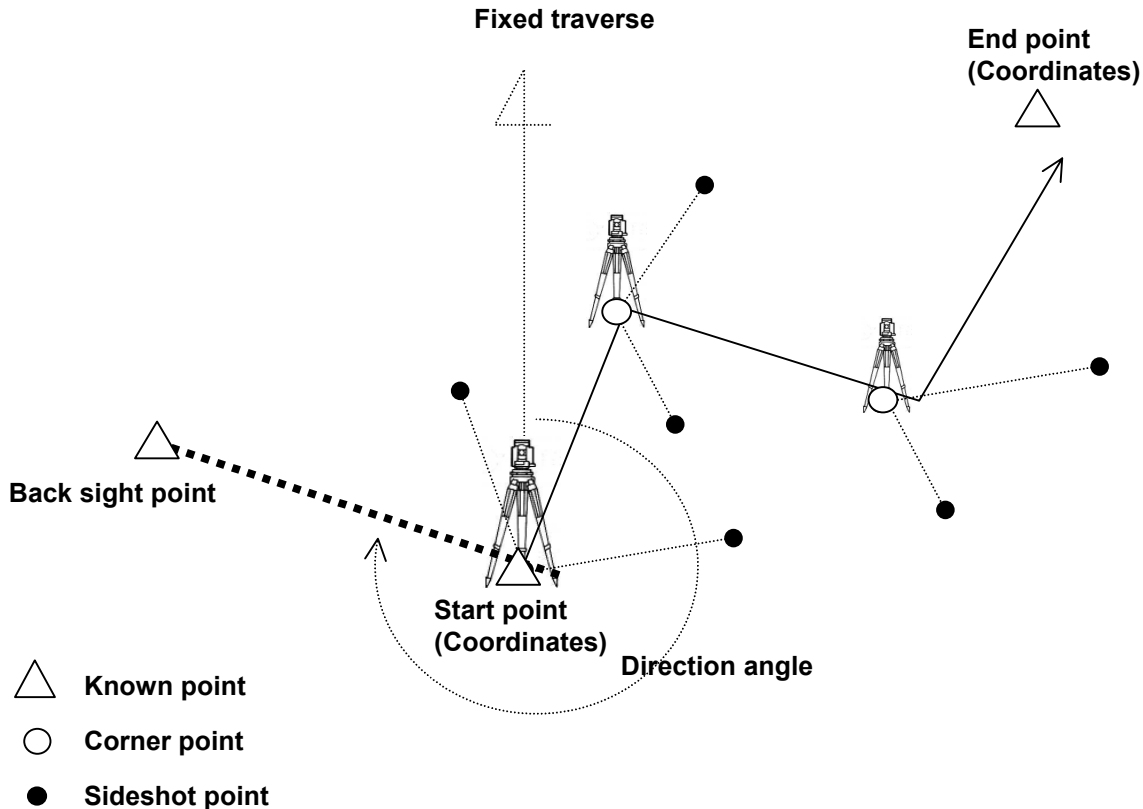

The following assumptions are made:

The current station is the fore sight point of the previous station which you select as a next station. The back sight point of current station is the previous station.

The following limitations are made.

More than one traverse route can't be measured at the same time.

Don't store other data while you are measuring the traverse route.

When one traverse route is finished, perform the traverse calculation before you store other data.

Don't turn the power supply off until the measurement at one start point or at one corner point is completed.

Don't escape from the MEASURE screen.

You can't use a duplicate PN in one Job. And you can't overwrite the PN in the traverse.

The same traverse route can't be calculated again.

Polar coordinates data of back sight and station points can't be seen in the [EDIT THE POLAR DATA](#) function. But it is sent properly in [SEND POLAR DATA](#) function.

Traverse

From the PowerTopoLite screen, Press the [F1][TRAV] of the PowerTopoLite screen to view the TRAVERSE screen.

11.1 Start point measuring

Select 1.START POINT first to start new traverse.

Note

More than one traverse route can't be measured at the same time.

Please start the new traverse route after another traverse route is finished.

TRAVERSE	
1. START POINT MEAS.	
2. CORNER POINT MEAS.	
3. FIXED CALC.	
4. CLOSED CALC.	
5. OPEN CALC.	
	↑ ↓

Press [ENT] to view the STATION POINT SETUP screen.

STATION POINT SETUP	
1. PN :	
2. IH :	0000.000 m
3. PC :	
4. TEMP :	27° C
5. PRESS :	994 hpa
↓	
	↑ ↓ ACCEPT

The ↑/↓ mark is used to scroll up / down. 6. PC is viewed by .

STATION POINT SETUP	
↑	
2. IH :	0000.000 m
3. PC :	
4. TEMP :	27° C
5. PRESS :	994 hpa
6. ppm :	16 ppm
	↑ ↓ ACCEPT

Point name, PN, input

Press [ENT] to view the PN screen.

PN	
1. PN	POT1
2. IH :	0000.000 m
3. PC :	
4. TEMP *	27° C
5. PRESS *	994 hpa
↓	
	← → BS CLEAR TO 123

IH, TEMP, PRESS, ppm and PC input
Input IH value.

IH	
1. PN :	POT1
2. IH :	0001.200 m
3. PC :	
4. TEMP * :	27° C
5. PRESS * :	994 hpa
<input type="button" value="↑"/> <input type="button" value="↓"/> <input type="button" value="ACCEPT"/>	

Press [ENT].

Press [ENT] and input the PC.

PC	
1. PN :	POT1
2. IH :	0001.200 m
3. PC :	
4. TEMP * :	27° C
5. PRESS * :	994 hpa
<input type="button" value="↑"/> <input type="button" value="↓"/> <input type="button" value="ACCEPT"/>	

Input the TEMP value.

Can't be changed is displayed.

STATION POINT SETUP	
1. PN :	POT1
2. IH :	0001.200 m
3. PC :	
4. TEMP :	Can't be changed
5. PRESS :	994 hpa
<input type="button" value="↑"/> <input type="button" value="↓"/> <input type="button" value="ACCEPT"/>	

Press [ENT].

Input the PRESS value.

Can't be changed is displayed.

STATION POINT SETUP	
1. PN :	POT1
2. IH :	0001.200 m
3. PC :	
4. TEMP * :	27° C
5. PRESS * :	Can't be changed
<input type="button" value="↑"/> <input type="button" value="↓"/> <input type="button" value="ACCEPT"/>	

Press [ENT].

Input the ppm value.

Can't be changed is displayed.

STATION POINT SETUP	
2. IH :	0000.000 m
3. PC :	
4. TEMP :	Can't be changed C
5. PRESS :	994 hpa
6. ppm :	16 ppm
<input type="button" value="↑"/> <input type="button" value="↓"/> <input type="button" value="ACCEPT"/>	

TEMP, PRESS and ppm input depend on the Initial setting 1 (AUTO, ATM INPUT, ppm INPUT, NIL).
Above Can't be changed is shown at AUTO of the above.

STATION POINT SETUP	
2. IH :	0000.000 m
3. PC :	
4. TEMP :	27° C
5. PRESS :	994 hpa
6. ppm :	16 ppm
<input type="button" value="↑"/> <input type="button" value="↓"/> <input type="button" value="ACCEPT"/>	

Press [F5][ACCEPT] to save the inputted data.

Then it proceeds to STATION POINT H. ANGLE SETUP screen automatically.

Station Orientation

Input the back sight point's direction angle from the start point.

Note

The direction angle set at this screen is used at the traverse calculation which will be executed later.

STATION POINT H. ANGLE SETUP			
H. angle	XXX°	XX'	XX"
<input type="button" value="INPUT"/> <input type="button" value="0 SET"/> <input type="button" value="HOLD"/> <input type="button" value="INVERS"/>			

And the rotation of the "H.angle" depend on the rotation setting of "[13.2 Coordinate axis definition](#)".

- [INVERS] key

If you want to calculate the direction angle, press [F5][INVERS] to jump [INVERSE](#) function.

Input SP as a start point and EP as a back sight point.

Result angle is set here automatically by pressing the [ENT] at the RESULT OF INVERSE screen.

Press [ENT] after aiming at the reference point.

Aim at the reference point and press [ENT] to view the MEASURE screen.

MEASURE	
PN	POT2
PH	0.000 m
H.angle	xxx° xx' xx"
V.angle	xx° xx' xx"
S.dst	
<input type="button" value="MEAS"/> <input type="button" value="SAVE"/> <input type="button" value="ME/SAVE"/> <input type="button" value="EDIT"/> <input type="button" value="PAGE"/>	

Measuring

Aim at the Target point and press [F1][MEAS] to measure the distance.

MEASURE	
PN	POT2
PH	0.000 m
H.angle	xxx° xx' xx"
V.angle	xxx° xx' xx"
S.dst	xx.xxx m
<input type="button" value="MEAS"/> <input type="button" value="SAVE"/> <input type="button" value="ME/SAVE"/> <input type="button" value="EDIT"/> <input type="button" value="PAGE"/>	

ENT

Press [F3][ME/SAVE] to measure and save the measured data as **sideshot point**.

Press [F2][SAVE] to save the measured data as **sideshot point**.

Press the [F4][EDIT] to edit the PN, Point Name, PH, Prism Height and PC, Point Code. Press [ENT] to view the each input window by pressing the up or down arrow key, and input your desired point name or prism height or point code. Press the [F5][ACCEPT], if the current PN, PH and PC are acceptable.

MEASURE	
1. PN:	POT100
2. PH:	000.500 m
3. PC:	
<input type="button" value="↑"/> <input type="button" value="↓"/> <input type="button" value="ACCEPT"/>	

Press the [ENT] to save the measured data as **corner point**

If [ENT] is pushed more than twice at the one station, the last [ENT] point becomes next corner point.

Note

Please use [SAVE] [ME/SAVE] and [ENT] properly by sideshot and corner point.

Press [F5][PAGE] to view another menu.

MEASURE	
PN	POT100
PH	0.500 m
H.angle	xxx° xx' xx"
V.angle	xxx° xx' xx"
S.dst	xx.xxx m
EDM	TARGET
	PAGE

11.2 Corner point measuring

Select 2.CORNER POINT to start measuring at corner point.

TRAVERSE	
1. START POINT MEAS.	
2. CORNER POINT MEAS.	
3. FIXED CALC.	
4. CLOSED CALC.	
5. OPEN CALC.	
	↑ ↓

And press [ENT] to view the STATION POINT SETUP screen.

STATION POINT SET UP	
1. PN :	POT2
2. IH :	0.000m
3. PC :	
	↑ ↓ ACCEPT

Press the [ENT] to view the AIM AT THE REFERENCE POINT screen.

AIM AT THE REFERENCE POINT.	
Aim at the reference point Press [ENT] when ready.	
ESC	ENT

Aim at the previous station, then press [ENT].
The direction angle is set automatically.
It proceeds to MEASURE screen automatically.

Measuring

Aim at the Target point and press [F1][MEAS] to measure the distance.

MEASURE	
PN	POT3
PH	0.000 m
H.angle	xxx° xx' xx"
V.angle	xxx° xx' xx"
S.dst	xx.xxx m
MEAS	SAVE
ME/SAV	EDIT
	PAGE

ENT

Press [F3][ME/SAVE] to measure and save the measured data as **sideshot point**.

Press [F2][SAVE] to save the measured data as **sideshot point**.

Press [F4][EDIT] to edit the PN, Point Name, PH, Prism Height and PC, Point Code. Press [ENT] to view the each input window by pressing the up or down arrow key, and input your desired point name or prism height or point code. Press the [F5][ACCEPT], if the current PN, PH and PC are acceptable.

MEASURE	
1. PN:	POT300
2. PH:	000.500 m
3. PC:	
<div style="display: flex; justify-content: space-between; align-items: center;"> ↑ ↓ ACCEPT </div>	

Press the [ENT] to save the measured data as **corner point**
 If [ENT] is pushed more than twice at the one station, the last [ENT] point becomes next corner point.

Note

Please use [SAVE] [ME/SAVE] and [ENT] properly by sideshot and corner point.

Press [F5][PAGE] to view another menu.

MEASURE	
PN	POT300
PH	0.500 m
H.angle	xxx° xx' xx"
V.angle	xxx° xx' xx"
S.dst	xx.xxx m
<div style="display: flex; justify-content: space-between; align-items: center;"> EDM TARGET PAGE </div>	

To finish the traverse measurement

Fixed traverse

Please measure the known point and press [ENT] at the last corner point.

Closed traverse

Please measure the start point and press [ENT] at the last corner point.

Note

Don't use the same point name (PN) for start point when you measure the start point from the last corner point.

For example, change " T1 " to " T1-1 " etc.

Open traverse

You do not need to measure the corner point by pressing [ENT] for calculation at the last corner point.

The closing errors are not calculated.

11.3 Calculation

Select "3.FIXED CALC." or "4. CLOSED CALC." or "5.OPEN CALC." to calculate the traverse route.

TRAVERSE	
1. START POINT MEAS.	
2. CORNER POINT MEAS.	
3. FIXED CALC.	
4. CLOSED CALC.	
5. OPEN CALC.	
<div style="display: flex; justify-content: space-between; align-items: center;"> ↑ ↓ </div>	

Press [ENT] to view the **START POINT COORD. SETUP** screen.

Start point coordinates setup

(Input the PN, Coordinates and PC of the Start point.)

START POINT COORD. SETUP				
1. PN:POT1				
2. X: +00000000.000 m				
3. Y: +00000000.000 m				
4. Z: + 00000000.000 m				
	LIST	↑	↓	ACCEPT

- [LIST] key

All the stored points can be displayed as follows by pressing [F2][LIST].

Press [F2][LIST] to view the **POINT SELECTION FROM THE LIST** screen.

POINT SELECTION FROM THE LIST				
1 / 15				
PN:POT1				
X: + 00000100.000 m				
Y: - 00000200.000 m				
Z: + 00000010.000 m				
↓	DELETE	FIND PN	↑	↓

Press [ENT] to open the X coordinate input screen.

Input your desired value by pressing each keys and press [ENT] to go Y coordinate.

START POINT COORD. SETUP				
1. PN:				
2. X: +00000000.000 m				
3. Y: +00000000.000 m				
4. Z: + 00000000.000 m				
←	→			CLEAR

Press [ENT] to open the Y coordinate input screen and input.

START POINT COORD. SETUP				
1. PN:				
2. X: +00000000.000 m				
3. Y: +00000000.000 m				
4. Z: + 00000000.000 m				
←	→			CLEAR

Press [ENT] to open the Z coordinate input screen and input.

START POINT COORD. SETUP				
1. PN:				
2. X: +00000000.000 m				
3. Y: +00000000.000 m				
4. Z: +00000000.000 m				
←	→	↑	↓	CLEAR

Only in the case of fixed traverse,
End point coordinates setup screen is displayed.

(Input the PN , Coordinates and PC of the End point.)

After Z coordinate input, END POINT COORD. SETUP screen is viewed.

END POINT COORD. SETUP	
1. PN:	
2. X:	+00000000.000 m
3. Y:	+00000000.000 m
4. Z:	+ 00000000.000 m
<div style="display: flex; justify-content: space-between; align-items: center;"> LIST ↑ ↓ ACCEPT </div>	

Input the PN, X, Y, Z Coordinates and PC name of the End point.

END POINT COORD. SETUP	
1. PN:	
2. X:	+00000000.000 m
3. Y:	+00000000.000 m
4. Z:	+00000000.000 m
<div style="display: flex; justify-content: space-between; align-items: center;"> ← → ↑ ↓ CLEAR </div>	

Press [ENT] to view the RESULT COORD. OF TRAVERSE screen.

RESULT COORD. OF TRAVERSE	
PN	XXXX
X	+X. XXX
Y	+X. XXX
Z	+X. XXX
e/s	X.XXX / X.XXX
<div style="display: flex; justify-content: space-between; align-items: center;"> ▲ ▼ ↑ ↓ ACCEPT </div>	

“ e / S ” indication means “ closing errors / total length “.

[F1] and [F2]s indicate only corner points in order.

[F3] and [F4]s indicate all points in order.

Press [F5][ACCEPT] to save the all corner, sideshot points, and known points.



12. INPUT / OUTPUT

The communication setting and the Input/Output of data are performed by this Function. There are 4 menu items in the Input/ Output menu. Perform the Communication setup before input from the PC or output from the PC.

We recommend you not to press any keys until data transfer is completed while transfer operation.

Notice concerning the unit of data to transfer

Sending the data (Rec. data & Polar data)

Coordinates and Distance data

The unit is outputted by m unit even if the distance unit setting of the instrument to send the data is m, ft and feetinch.

Angle, Temperature and Pressure data

The data is outputted according to the unit setting of the Angle, Temperature and Pressure of the instrument to send the data.

Receiving the data (Rect. data)

Coordinates data

The Coordinates data received is inputted in the instrument as data of "m" unit. And then, it is converted according to the distance unit which is set in the instrument, and displayed on the screen.

12.1 Input from the PC

The Rect. data is sent from the PC etc. and stored in the internal memory of the instrument. Press the [F3][I/O] of the PowerTopoLite screen to view the TRANSFER screen.

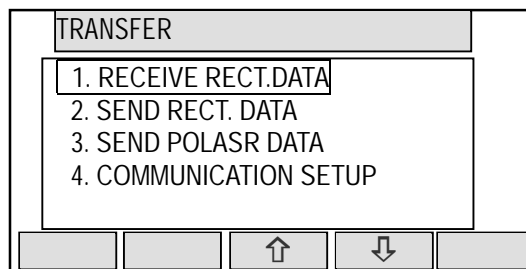

Select the 1. RECEIVE RECT. DATA and press [ENT] to view FORMAT SELECTION screen.

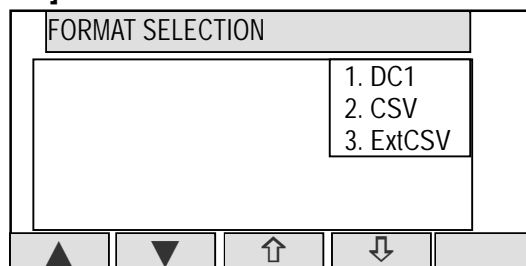

Select the DC1 format and press [ENT] to view DATA RCV. CONFIRMATION screen.
(Same procedure is performed at CSV.)

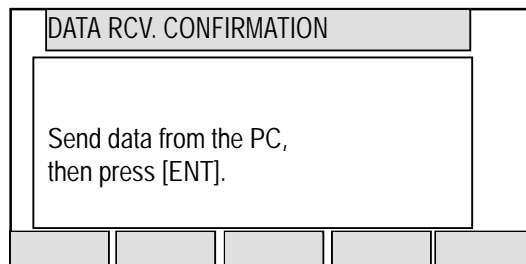

Set the PC to be ready to send and press [ENT] to receive the data from the PC

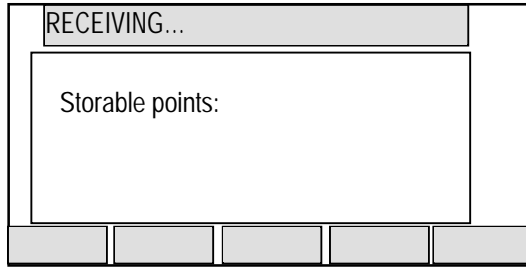

12.2 Output to the PC

The data stored in the internal memory is sent to the PC etc.

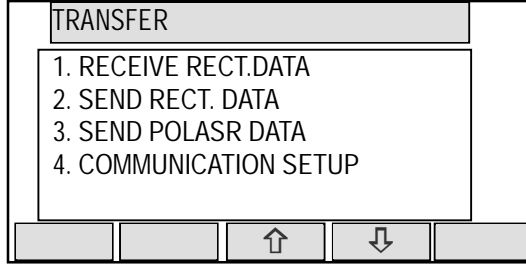

[RECT. DATA]

Select the 2. SEND RECT. DATA by pressing the down arrow key, and press [ENT] to view the FORMAT SELECTION screen.

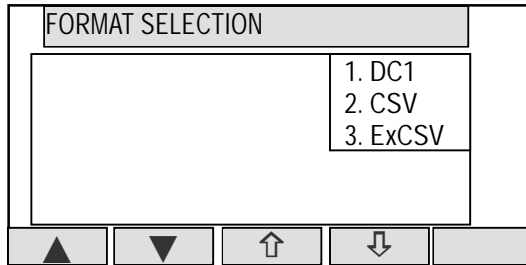

Select DC1 format and press [ENT] to view the DATA SEND. CONFIRMATION screen.
(Same procedure is performed at CSV)

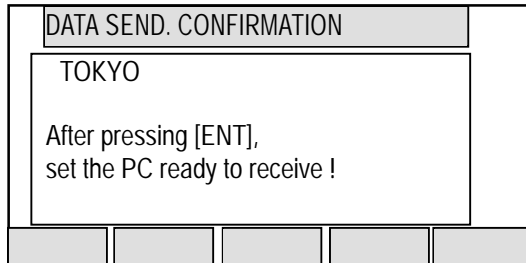

Press [ENT], and set the PC to be ready to receive.

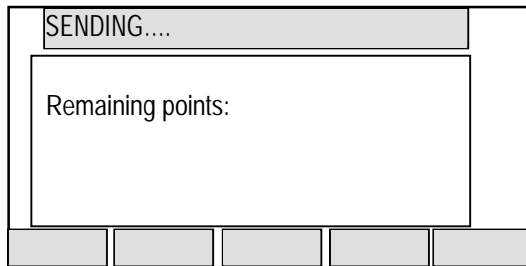

[POLAR DATA]

Select the 3. SEND PLAR DATA by pressing the down arrow key, and press [ENT] to view the FORMAT SELECTION screen.

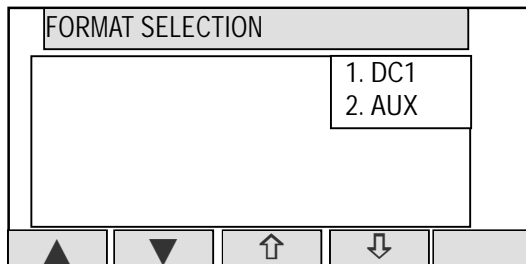

Select DC1 format and press [ENT] to view the **DATA SEND. CONFIRMATION** screen.
 (Same procedure is performed at AUX)

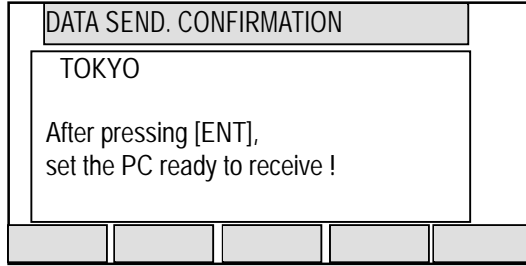

Press [ENT], and set the PC to be ready to receive.

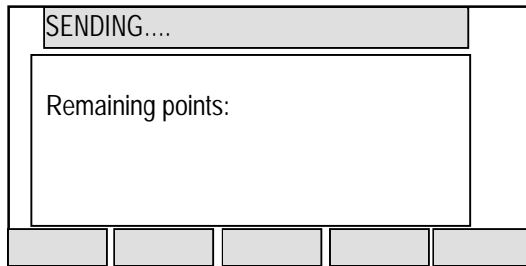

12.3 Communication setup

The communication parameter is set when stored data is received or sent between the instrument and the PC etc.

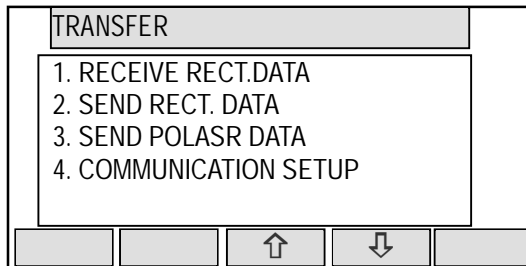

12.3.1 Receiving data setting

Select the 4. **COMMUNICATION SETUP** and press [ENT] to view the **COMM. SETTING SELECTION**.

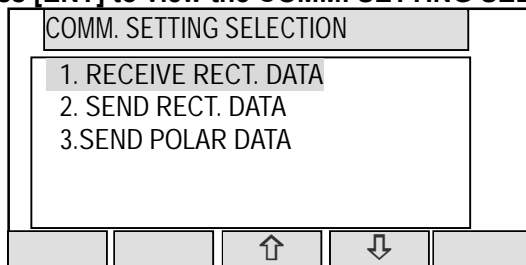

[1. RECEIVE RECT. DATA]

Select the 1. **RECEIVE RECT. DATA** and press [ENT] to view the following screen. Press [ENT] to open the selection window.

Select each setting and press [ENT].

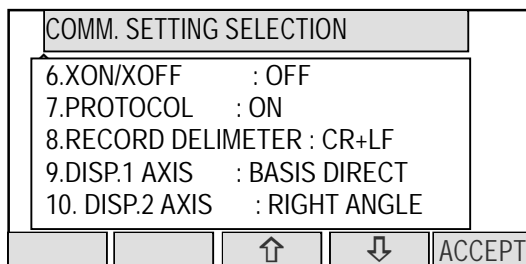
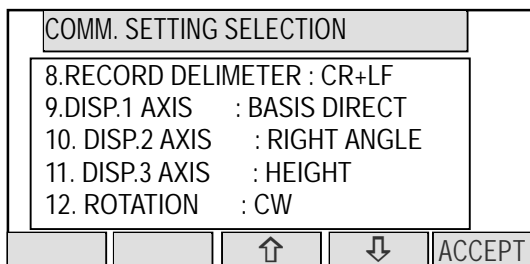
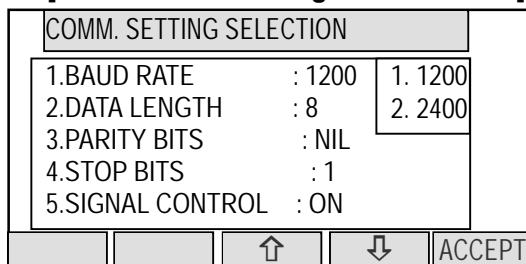

Press [ACCEPT] to enter when all selections are finished.

- **DISP.# AXIS: BASIS DIRECT., RIGHT ANGLE, or HEIGHT** is selected when data is transferred between the TS and PC. (cf. "[13.2 Coordinate axis definition](#)")
They are used for matching coordinate system between definition in the instrument and definition in the external device when they are different. However, it is necessary to match the definition of the "Coord. Axis" between settings in "[Communication setup](#)" and settings in "[Coordinate axis definition](#)" when same coordinate systems are used.
- **Factory default setting of RECEIVING**

1.BAUD RATE:	1200
2.DATA LENGTH:	8
3.PARITY BITS:	NIL
4.STOP BITS:	1
5.SIGNAL CONTROL:	ON
6.XON/XOFF:	ON
7.PROTOCOL:	ON
8.RECORD DELIMETER:	CR+LF
9.DISP.1 AXIS:	BASIS DIRECT
10. DISP.2 AXIS:	RIGHT ANGLE
11. DISP.3 AXIS:	HEIGHT
12. ROTATION:	CW

12.3.2 Sending data setting

Select the 4. COMMUNICATION SETUP and press [ENT] to view the COMM. SETTING SELECTION.

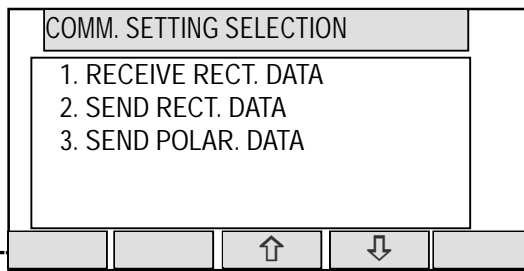

[2. SEND RECT. DATA]

Select the 2. SEND RECT. DATA and press [ENT] to open the selection window.

Select each setting and press the [ENT].

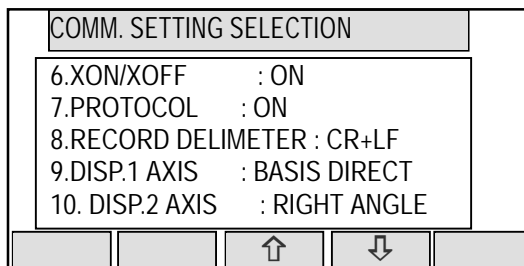
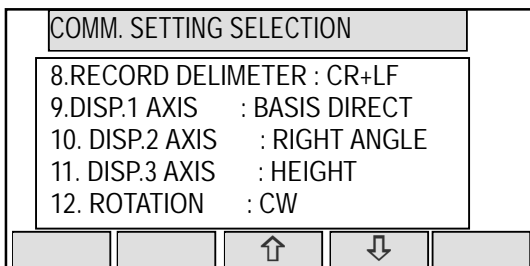
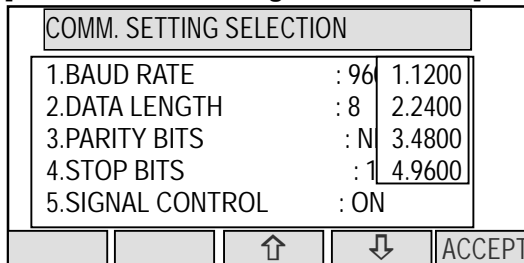

Press [ACCEPT] to enter when all selections are finished.

- **DISP.# AXIS: BASIS DIRECT, RIGHT ANGLE, or HEIGHT** is selected when data is transferred between the TS and PC. (cf. "[13.2 Coordinate axis definition](#)")
They are used for matching coordinate system between definition in the instrument and definition in the external device when they are different. However, it is necessary to match the definition of the "Coord. Axis" between settings in "[Communication setup](#)" and settings in "[Coordinate axis definition](#)" when same coordinate systems are used.

- **Factory default setting of SENDING**
 - 1.BAUD RATE: 9600
 - 2.DATA LENGTH: 8
 - 3.PARITY BITS: NIL
 - 4.STOP BITS: 1
 - 5.SIGNAL CONTROL: ON
 - 6.XON/XOFF: ON
 - 7.PROTOCOL: ON
 - 8.RECORD DELIMETER: CR+LF
 - 9.DISP.1 AXIS: BASIS DIRECT
 10. DISP.2 AXIS: RIGHT ANGLE
 11. DISP.3 AXIS: HEIGHT
 12. ROTATION: CW

[3. SEND POLAR DATA]

Select the 3. SEND POLAR DATA and press [ENT] to view the following screen. Press [ENT] to open the selection window.
Select each setting and press the [ENT].

COMM. SETTING SELECTION	
1.BAUD RATE	: 9600 1.1200
2.DATA LENGTH	: 8 2.2400
3.PARITY BITS	: N 3.4800
4.STOP BITS	: 4.9600
5.SIGNAL CONTROL	: ON
ACCEPT	

COMM. SETTING SELECTION	
3.PARITY BITS	: NIL
4.STOP BITS	: 1
5.SIGNAL CONTROL	: ON
6.XON/XOFF	: ON
7.ROTATION	: CW
<div style="display: flex; justify-content: space-around; width: 100%;"> ↑ ↓ </div>	

Press [ACCEPT] to enter when all selections are finished.

- **Factory default setting of 3. SEND POLAR DATA**
 - 1.BAUD RATE: 9600
 - 2.DATA LENGTH: 8
 - 3.PARITY BITS: NIL
 - 4.STOP BITS: 1
 - 5.SIGNAL CONTROL: ON
 - 6.XON/XOFF: ON
 - 7.ROTATION : CW

12.4 About DataLink DL- 01 Software

DataLink DL01 Software allows you to send collected data by R-300 to other devices, to receive coordinates data, and to convert the resulting files into a number of common formats.

a) Recommendation for "PN"

It is recommended that "PN" (Point Name) data should consist of less or equal to 4 (one-byte) numeric characters to convert files with DL-01.

Because, it may not be converted properly if alphabetic characters or more than 5 (one-byte) numeric characters are used for the "PN".

b) Notes for the data transferring.

Please, be careful about following items for the data transfer with "DL-01".

b-1 Type of data, which can be transferred.

With PTL, "POLAR DATA" can be transferred by "DC1" or "AUX" format.

In addition, it is possible DL-01 to receive/convert "POLAR DATA" with "DC1 (DC-1Z)" format.

b-2 Notes for unit.

If you are requested to select unit when you convert data on DL-01, please select unit according to the settings on R-300.

b-3 Limitation for each format.

Please, use "CSV" or "DC1(DC-1Z) " format to transfer data to/from R-300.

Limitation for the "CSV" format.

With the "CSV" format, "PN" and "PC" (Point Code) data consist of less or equal to 15 (one-byte) characters can be transferred.

Limitations for the "DC1 (DC-1Z)" format.

With "DC1 (DC-1Z)" format, the length of "PN" data should consist of less or equal to 11 (one-byte) characters. And with the "DC1 (DC-1Z)" format "PC" data cannot be transferred.

b-4 Recommended communication settings on R-300.

Recommended settings for "[COMM SETTING SELECTION](#)" on R-300 special function is as follows.

R-300⇒PC(DL-01) to "SEND RECT. DATA"

1.BAUD RATE:	1200
2.DATA LENGTH:	8
3.PARITY BITS:	NIL
4.STOP BITS:	1
5.SIGNAL CONTROL:	OFF
6.XON/XOFF:	OFF
7.PROTOCOL:	OFF for "CSV" format, ON for "DC1 (DC-1Z)" format
8.RECORD DELIMETER:	CR+LF
Subsequent items:	As you like.

R-300⇒PC(DL-01) to "SEND POLAR DATA"

1.BAUD RATE:	1200-9600
2.DATA LENGTH:	8
3.PARITY BITS:	NIL
4.STOP BITS:	1
5.SIGNAL CONTROL:	OFF
6.XON/XOFF:	OFF
7.ROTATION:	As you like.

PC(DL-01)⇒R-300 to "RECEIVE RECT. DATA"

1. BAUD RATE: 1200
2. DATA LENGTH: 8
3. PARITY BITS: NIL
4. STOP BITS: 1
5. SIGNAL CONTROL: OFF
6. XON/XOFF: OFF
7. PROTOCOL: OFF for "CSV" format, ON for "DC1 (DC-1Z)" format
8. RECORD DELIMETER: CR+LF
9. Subsequent items: As you like.

Please note that these settings should be common with DL-01's.

b-5 Recommended communication settings on DL-01.

To configure DL-01 Communication setting, please read "Configuring the software" in the Help topics of DL-01. And select values as follows.

For setting "Type of Device" in the "Settings" panel (Menu—"Edit"--"Settings"), select "R-100 (PTL) / R-300(PTL)" for "R-300 PowerTopoLite" and other setting should be as follows.

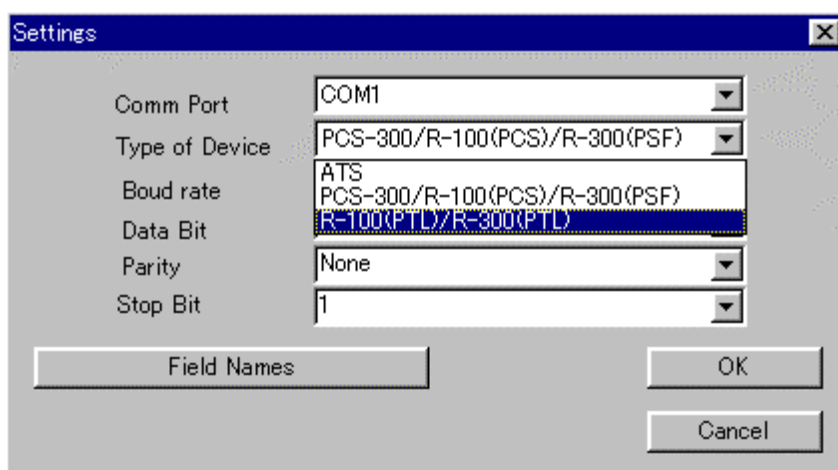

(Please note that these settings should be common with R-300's. And if the selection of "Type of Device" is not collect it may result in missing some data.)

R-300⇒PC(DL-01)

- | | | |
|------------------|------|--------------------------------------|
| Bits per second: | 1200 | (1200-9600 for sending "POLAR DATA") |
| Databits: | 8 | |
| Parity: | None | |
| Stop bits: | 1 | |

PC(DL-01)⇒R-300

- | | |
|------------------|------|
| Bits per second: | 1200 |
| Databits: | 8 |
| Parity: | None |
| Stop bits: | 1 |

c) Note for the Memory capacity.

Data transfer failure from DL01 to R-300 may cause reduction of memory capacity. If memory capacity becomes less, please back up required data first, and then initialize coordinates data. To initialize coordinates data, turn on the instrument while pressing [F2]+[F5]+[ON/OFF], and take your finger off from [ON/OFF] again. After you see the message "COORD. DATA INITIAL", press [F5]. Then the message "Please, wait" is displayed. When it is completed, the panel of Electronic Vial is displayed.

- d) Difference between CSV format on “PentaxSpecialFunction” and “PowerTopoLite”. CSV file format from R-300 “PentaxSpecialFunction” version is slightly different from “PowerTopoLite” version as follows.

Type of software version	Format
R-300 “PentaxSpecialFunction” version	PN, X, Y, Z, Code
R-300 “PowerTopoLite” version	PN, X, Y, Z, Code,

At the end of each line of CSV file output by “PowerTopoLite”, there is “,” as shown above.

- e) Note on converting CSV file.

When you attempt to convert CSV file from R-300 by DL-01, please note that it may not succeed if CSV data type is not correct.

After [CONVERT] button is clicked on DL-01 then “CSV files from PCS/R-100 (*.*)” is selected for the type of file, “CSV Import Option” will be appear.

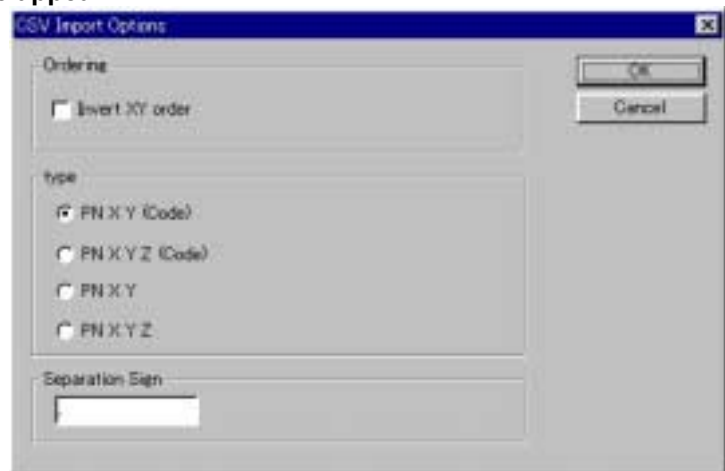

In the case of CSV data doesn't have “CODE” field, please select “PN XY” or “PN XYZ” from following four types for the “type” of data on the “CSV Import Option” panel.

- PN XY (Code)
- PN XYZ (Code)
- PN XY
- PN XYZ

- f) For more information to work with DL-01, please refer to the "help" file after the installation.



13. PREFERENCE

Followings are possible function and the factory default settings.:

FUNCTION	Default settings
A Language other than the English can be selected.	"English"
Coordinate system can be selected.	(cf. Coordinate axis definition)
Character input method can be selected.	"FULL TEMPLATE"
Action input method can be selected.	"PROCESS TYPE"
The offset (remote) method can be selected.	"FIXED PLANE"
Compare method can be selected.	"ALL IN ONE VIEW"
Aiming on/off can be selected.	"OFF"
EDM (electronic distance meter) settings can be selected. PRIM. MEAS KEY, SEC. MEAS KEY, MEAS. MIN DISP (only R322/N, R323/N), TRACK MIN DISP, SHOT COUNT, SHOT INPUT.	"MEAS. SHOT" "TRACK CONT" "COARSE" "COARSE" "1 TIME" "01 TIME"
Elevation factor can be defined. AVE.ELEV. SCALE FACT	+0000.0000m 1.00000000

Press [F4][PREF] of the PowerTopoLite screen to view the PREFERENCE screen.

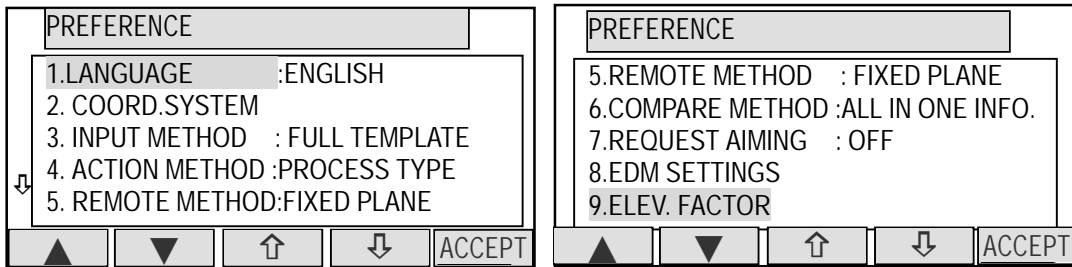

13.1 Language selection

Select 1. LANGUAGE and press [ENT] to view the LANGUAGE selection window.

Press [ENT] to select and press [F5][ACCEPT] to enter.

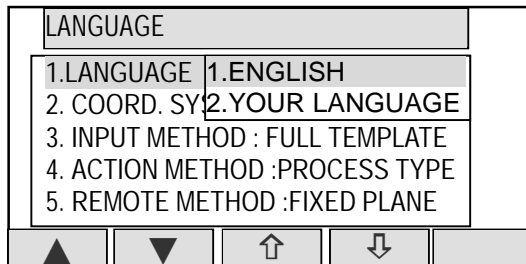

13.2 Coordinate axis definition

Select 2. COORD.AXIS by pressing the down arrow key, and press [ENT] to view the coordinate system definition window. Press [ENT] to select and press [F5][ACCEPT] to enter.

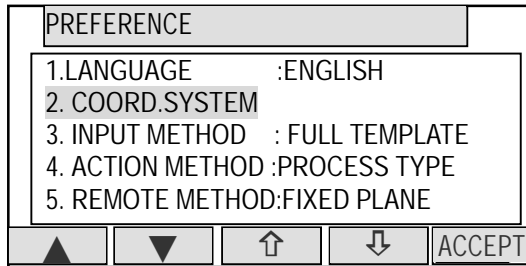
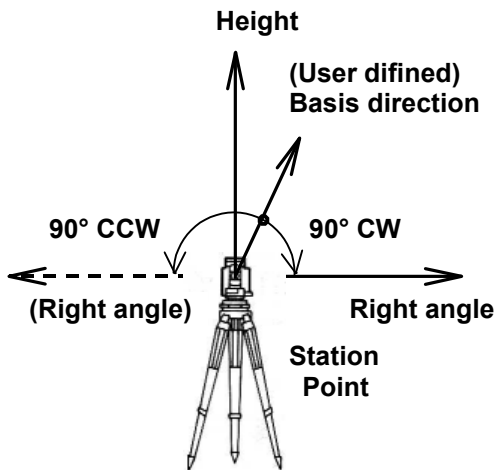

Definition of each selection is as follows.

Item	Description	Selection	Default	ex.1 German XYZ	ex.2	ex.3
1. DISP.1 NAME	Name of the 1st Axis on the screen. (Ex. It is shown 3rd line of the "MEASURE" screen.)	Any name	X	X	N	E
2. DISP.2 NAME	Name of the 2nd Axis on the screen. (Ex. It is shown 4th line of the "MEASURE" screen.)	Any name	Y	Y	E	N
3. DISP.3 NAME	Name of the 3rd Axis on the screen. (Ex. It is shown 5th line of the "MEASURE" screen.)	Any name	Z	Z	Z	Z
4. DISP.1 AXIS	Define the direction of the 1st Axis.	1. BASIS DIRECTION 2. RIGHT ANGLE 3. HEIGHT	1. BASIS DIRECTION	2. RIGHT ANGLE	1. BASIS DIRECTION	1. BASIS DIRECTION
5. DISP.2 AXIS	Define the direction of the 2nd Axis.	1. BASIS DIRECTION 2. RIGHT ANGLE 3. HEIGHT	2. RIGHT ANGLE	1. BASIS DIRECTION	2. RIGHT ANGLE	2. RIGHT ANGLE
6. DISP.3 AXIS	Define the direction of the 3rd Axis.	1. BASIS DIRECTION 2. RIGHT ANGLE 3. HEIGHT	3. HEIGHT	3. HEIGHT	3. HEIGHT	3. HEIGHT
7. ROTATION	Define the rotation from the 1 Axis to the 2 Axis..	1. CW 2. CCW	1. CW	1. CW	1. CW	1. CCW
Example of GRAPHICAL VIEW						

Any name can be defined for each three axis.

For the "DISP.# NAME", it is possible to define same name. However, please note that the same coordinates value will be displayed.

DISP.1 NAME	
1.	DISP.1 NAME :X
2.	DISP.2 NAME :N
3.	DISP.3 NAME :Z
4.	DISP.1 AXIS :BASIS DIRECT.
5.	DISP.2 AXIS :RIGHT ANGLE

← → BS CLEAR TO 123

Three type of the axis can be selected for each three axis.

For the "DISP.# AXIS", it is possible to define same type of axis. However, please note that the same coordinates value will be displayed.

DISP.1 AXIS		
3.	DISP.3 NAME :Z	1.BASIS DIRECT.
4.	DISP.1 AXIS :BASIS	2.RIGHT ANGLR
5.	DISP.2 AXIS :RIGH	3.HEIGHT
6.	DISP.3 AXIS :HEIGHT	
7.	ROTATION :CW	

← → BS CLEAR TO 123

Definition of this function will be affected to the value of the coordinates.

MEASURE	
PN	
PH	+0.000 m
N	+0.000 m
E	+0.000 m
Z	+0.000 m

← → BS CLEAR TO 123

Please, note that the up on the screen of the graphical view always shows "BASIS DIRECTION".

In addition, position of points doesn't change on the "GRAPHICAL VIEW" but, value of coordinates changes according to the setting of "Coordinate axis definition".

↑ BASIS DIRECTION	

← → ↑ ↓ PAGE

13.3 Input method selection

Select 3. INPUT METHOD and press [ENT] to view the Character INPUT METHOD selection window. Press [ENT] to select and press [F5][ACCEPT] to enter.

INPUT METHOD	
1. LANGUAGE	1. 10 KEY SYS.(ABC)
2. COORD. SYSTEM	2. 10 KEY SYS.(123)
3. INPUT METHOD	3. FULL TEMPLATE
4. ACTION METHOD	4. DIVIDED TEMPLATE
5. REMOTE METHOD	5. MATRIX SYSTEM

Explanation of the 10 Key system(123/ABC), Full template, Divided template and Matrix system.

1. 10 KEY SYSTEM(123/ABC)

These are the standard input method using the Alphanumeric and +/- key.

PN	
1. PN:	P-1
2. X:	+ 00000000.000 m
3. Y:	+ 00000000.000 m
4. Z:	+ 00000000.000 m
5. IH:	0000.000 m

2. Full template

Select each Character by pressing left, right, up and down arrow keys and select each Character by pressing [F5][SELECT] each time.

PN	
ABCDEFGHIJKLMNOPQRSTUVWXYZ ←⇒ abcdefghijklmnopqrstuvwxyz SP BS 0123456789 ., ?! () " ' ; + - * / & = % CLR	

3. Divided template

PN	
<input type="text" value="ABCDEFGHIJKLMNOPQR"/>	
<input type="text" value="A"/>	

4. MATRIX

<input type="text" value="A....."/>				
R1: 1Aa, 2Bb, 3Cc?, 4Dd! 5Ee# R2: 6Ff(7Gg 8Hh R3: KkL R4: Uu+:				
<input type="button" value="R1"/>	<input type="button" value="R2"/>	<input type="button" value="R3"/>	<input type="button" value="R4"/>	<input type="button" value="R5"/>

How to input "A" by Matrix.

First, Press [F1][R1] to view next screen.

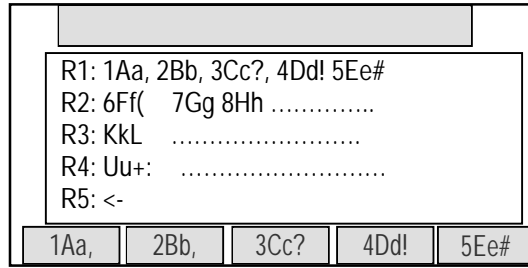

Press [F1][1Aa] to view next screen.

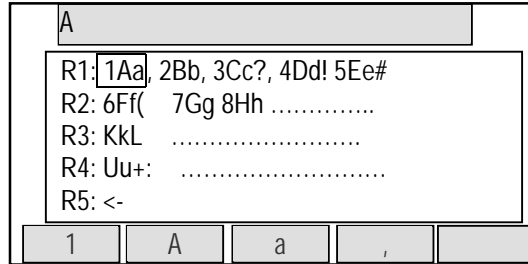

Press [F2][A] to select "A".

13.4 Action method selection

Select 4. ACTION INPUT METHOD and press [ENT] to view the Character ACTION INPUT METHOD selection window. Press [ENT] to select and press [F5][ACCEPT] to enter.

INPUT METHOD	
1. LANGUAGE	1. PROCESS TYPE
2. COORD. SYST	2. STRUCTURE TYPE
3. INPUT METHOD	:FULL TEMPLATE
4. ACTION METHOD	:PROCESS TYPE
5. REMOTE METHOD	:FIXED PLANE

Navigation buttons: ▲ ▼ ▲ ▼

Process type

This input method took over functionality of “PowerTopoLite”. When this option is selected, the next screen will be shown after inputting necessary items.

STATION POINT SETUP	
1. PN:	
2. X: +	00000100.000 m
3. Y: +	00000310.000 m
4. Z: +	00000110.000 m
5. IH: +	0000.000 m

Navigation buttons: SAVE LIST ▲ ▼ ACCEPT

Structure type

This input method took over functionality of “PCS-300”. When this option is selected, the menu screen will be shown after inputting necessary items.

RECTANGULAR COOR.	
1. STATION	
2. AZIMUTH	
3. MEASURE	

Navigation buttons: ▲ ▼

13.5 Remote method selection

Select 5. REMOTE METHOD and press [ENT] to view the REMOTE METHOD selection window. Press [ENT] to select and press [F5][ACCEPT] to enter.

REMOTE METHOD	
1. LANGUAGE	1. CYLINDER FACE
2. COORD. SYSTEM	2. FIXED PLANE
3. INPUT METHOD	3. ROTATED PLANE
4. ACTION METHOD :PROCESS TYPE	
5. REMOTE METHOD:FIXED PLANE	

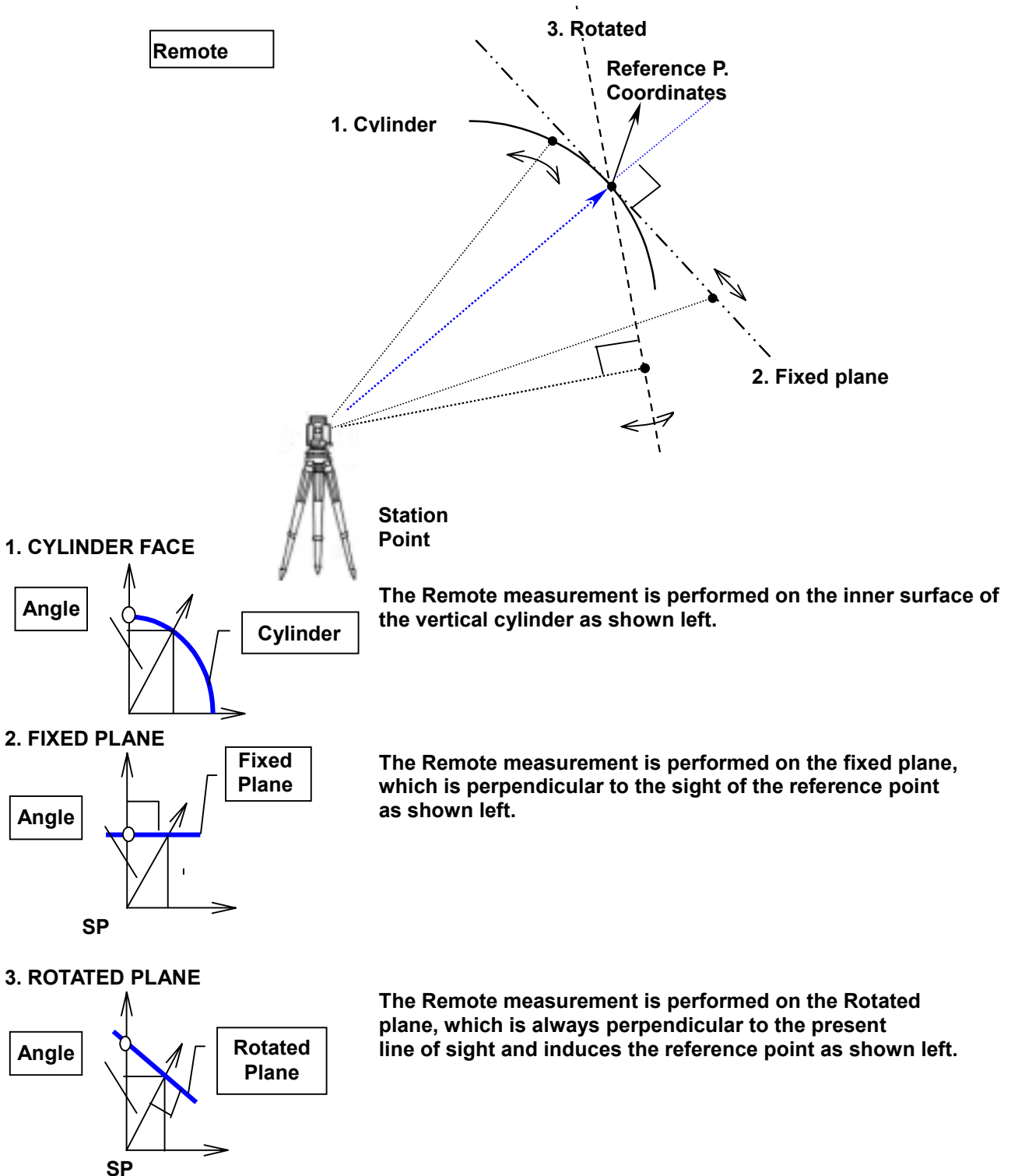

13.6 Compare method selection

Select 6. COMPARE METHOD SELECTION and press [ENT] to view the COMPARE METHOD selection window. Press [ENT] to select and press [F5][ACCEPT] to enter.

PREFERENCE	
5.REMOTE MET PLANE	1.ALL IN ONE INFO. 2.LARGE CHARACTER
6.COMPARE METHOD:ALL IN ONE INFO.	
7.REQUEST AIMING : OFF	
8.EDM SETTINGS	

▲ ▼ ↑ ↓ ACCEPT

When "ALL IN ONE INFO" is selected, all information will be displayed on the result of stakeout panel.

STAKEOUT	
PN	POT4
PH	X. XXX m
D H.angle	XXX° XX' XX"
D V.angle	- X° XX' XX"
D X	+X. XXX m
D Y	-X. XXX m
D Z	+X. XXX m

MEAS TARGET NEXT PAGE

When "LARGE CHARACTER" is selected, result information is shown with two screens and these screens and the Graphics screen can be switched by [ENT].

STAKEOUT	
PN	POT4
PH	X. XXX m
D H.angle	XXX° XX' XX"
D V.angle	- X° XX' XX"
D H. dist.	- m

MEAS TARGET NEXT PAGE

STAKEOUT	
PN	POT4
PH	X. XXX m
D X	+X. XXX m
D Y	-X. XXX m
D Z	+X. XXX m

MEAS TARGET NEXT PAGE

13.7 Request aiming selection

Select 7. REQUEST AIMING and press [ENT] to view the REQUEST AIMING selection window. Press [ENT] to select and press [F5][ACCEPT] to enter.

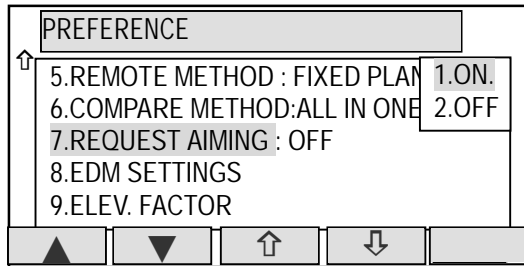

Pressing the [ENT] after entering the Horizontal angle, the AIM AT THE REFERENCE POINT screen is viewed when 1. ON is selected and not viewed when 2. OFF is selected without Coordinates input of BSP.

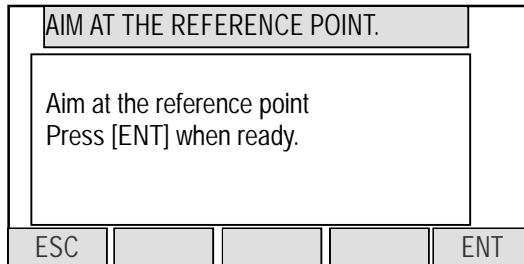

13.8 EDM settings selection

Select 8. EDM SETTINGS and press [ENT] to view the EDM SETTINGS selection window. Press [ENT] to select and press [F5][ACCEPT] to enter.

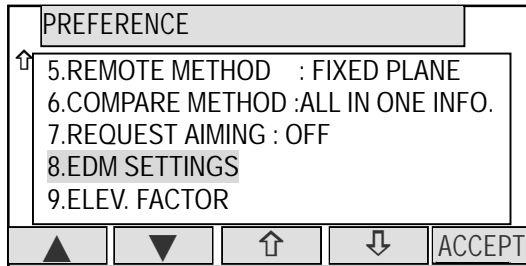

(Only R-322/N, 323/N)

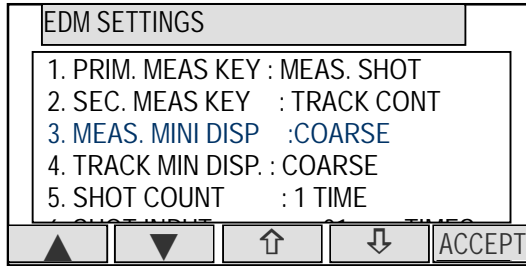
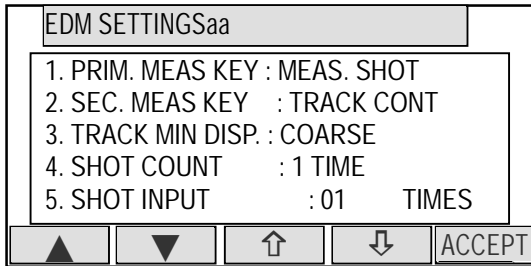

1. PRIM. MEAS KEY	1. MEAS. SHOT
	2. MEAS. CONT
	3. TRACK SHOT
	4. TRACK CONT
2. SEC. MEAS KEY	1. TRACK CONT
	2. TRACK SHOT
	3. MEAS. CONT
	4. MEAS. SHOT
3. MEAS. MIN DISP.	1. COARSE
	2. FINE
4. TRACK. MIN DISP	1. COARSE
	2. FINE
5. SHOT COUNT	1. 1 TIME
	2. 3 TIMES
	3. 5 TIMES
	4. INPUT
6. SHOP INPUT	XX TIME

(Only R-322/N, 323/N)

Please refer to the instruction manual of basic function about details of each setting.

13.9 Elevation Factor

“Elevation Factor” as used here refers to Average Elevation Correction and Scale Factor carried out as part of the measurement process among the special functions. It is effective only with MEAS-Rect., FREE, CALC-Traverse, and VPM. These reverse corrections are carried out with STAK (Stakeout, Point To Line). When the instrument is shipped from the factory, the 1. AVE.ELEV. is set to “0” and the 2. SCALE FACT to “1” so that no correction is carried out. If correction is necessary, input the appropriate values for the AVE.ELEV and SCALE FACT.

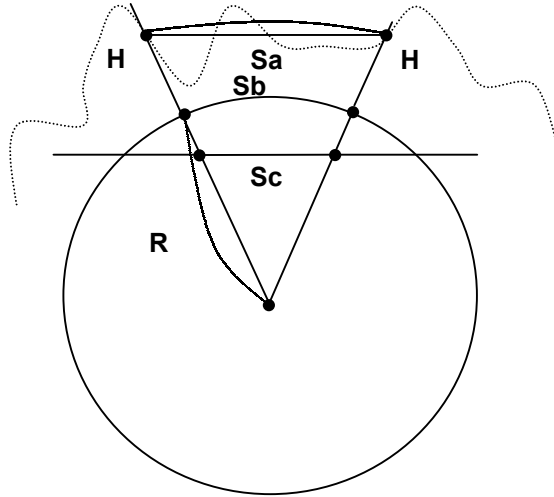

Cross section of the earth

Select 9. Elevation factor and press [ENT] to view the ELEVATION FACTOR selection window. Press [ENT] to select and press [F5][ACCEPT] to enter.

PREFERENCE				
↑	5.REMOTE METHOD : FIXED PLANE			
	6.COMPARE METHOD:ALL IN ONE INFO.			
	7.REQUEST AIMING : OFF			
	8.EDM SETTINGS			
	9.ELEV. FACTOR			
▲	▼	↑	↓	ACCEPT

1. Average Elevation

Average (H) = Averaged on-site elevation
Input range: -9999.9998 --+9999.9998m

ELEV.FACTOR				
1. AVE.ELEV. :	+0000.0000m			
2. SCALE FACT:	100000000			
▲	▼	↑	↓	ACCEPT

2. Scale Factor

Scaling= On-site scaling coefficient
Input range: +0.0000001 -- +1.9999998

ELEV.FACTOR				
1. AVE.ELEV. :	+0000.0000m			
2. SCALE FACT:	1.00000000			
▲	▼	↑	↓	ACCEPT

PENTAX

PENTAX Industrial Instruments CO., LTD.
2-5-2, Higashi-Oizumi, Nerima-ku
Tokyo 178-0063, Japan
Tel : +81-3-5905-1222
Fax: +81-3-5905-1225

E-mail: international@piic.pentax.co.jp

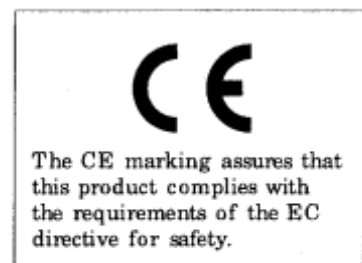

Member symbol of the Japan Surveying Instruments Manufacturers' Association representing the high quality surveying products.

102002 First edition
040303 2nd edition
TS01101EB1