

Electronic Quick Reference Guide Total Station



R-322N	R-322	Basic Procedures for R-300 Series
R-323N	R-323	The reflectorless function is applied to
R-325N	R-325	R-322N, R-323N, R-325N, R-335N, R-315N
R-335N	R-335	
R-315N	R-315	
	R-326	

PENTAX Precision Co., Ltd.

2-5-2 Higashi-Oizumi / Nerima-ku, Tokyo 178-8555, Japan
Tel. +81-3-5905-1222 / Fax +81-3-5905-1225

E-mail: international@ppc.pentax.co.jp

Web site: <http://www.pentax.co.jp/ppc/>

Electronic Total Station

Quick Reference Guide Basic Procedures for R-300 series

R-322N, R-323N, R-325N, R-335N, R-315N, R-322, R-323, R-325, R-335, R-315, R-326

The description concerning the reflectorless function
in this guide is applied to
R-322N, R-323N, R-325N, R-335N, R-315N.

PENTAX Precision Co., Ltd.

CONTENTS

General	6
Instruction Manuals	6
Precautions regarding safety	6
Warning	6
Usage Precautions	7
1 Basic Operation	9
1.1 Removing the Battery	9
1.2 Attaching the Battery	9
1.3 Turning the Power On and Off	9
1.4 Centering and Leveling	9
1.5 Target Sighting (Focusing)	10
1.5.1 Auto-Focus	10
1.5.2 Power Focus	10
1.5.3 Manual Focus	10
1.5.4 Continuous AF mode	10
1.6 Angle Measurement	11
1.6.1 Horizontal Angle	11
1.6.2 Vertical Angle	11
1.7. Distance Measurement	12
1.7.1 Select your target	12
1.7.2 Distance Measurement	12
1.7.3 Changing Target constants	12
1.7.4 Input Temperature and Atmospheric pressure	13
1.7.5 Laser pointer	13
1.7.6 Adjusting Laser Plummet brightness	13
1.7.7 Adjusting LCD contrast	13
1.7.8 Adjusting Illumination brightness	14
2 Changing Instrument Settings	15
3 Basic Field Checking Procedures	16
3.1 Electronic Vial	16
3.2 Laser Plummer	16
3.3 Laser Pointer	16
3.4 Error Messages	17
4 Specifications	18
Notice to the user of this product	20

Instruction Manuals

Quick Reference Guide is intended to provide a quick reference in the field. For ease of use in the field, the following Quick Reference Guide booklets are provided in the carrying case.

1. Basic procedure
2. PowerTopoLite for R-300 series, Operating procedure
3. PSF software for R-300 series, Operating procedure

The complete instruction manuals are contained on the CD that is attached to each R-300.

This guide uses the symbol “xN” as an expression of repeating times of key operation. For example. “ x2” means that [ESC] key is pressed two times.

The symbol “+” expresses that multiple keys are pressed simultaneously.

PRECAUTIONS REGARDING SAFETY

Before using this product, be sure that you have **thoroughly read and understood the instruction manual** that is included in the attached CD-ROM to ensure proper operation.



WARNING

WARNING



WARNING

Solar Observation

Never view the sun directly using the telescope as this may result in loss of sight.

Laser Safety

R-300N is a class-IIIa (3R) Laser product. Avoid direct eye exposure. R-300 without “N” is a class-II (2) Laser product. Do not stare into laser beam.

Electro-Magnetic Compatibility (EMC)

This instrument complies with the protection requirement for residential and commercial areas. If this instrument is used close to industrial areas or transmitters, the equipment can be influenced by electromagnetic fields.

Risk of Explosion

Do not use this product in a location where there is coal dust, or near flammable material as there is a risk of explosion.

USAGE PRECAUTIONS

Target Constant

Confirm the Target Constant of the instrument before measurement.

Reflectorless and Reflecting sheet

The reflectorless measurement range may vary depending on the target and surrounding brightness.

In case the reflectorless measurement results in low accuracy, perform the distance measurement by Reflector sheet or Prism. (R-322N, R-323N, R-325N, R-335N, R-315N,)

Battery & Charger

Use the battery charger that is suitable to the battery you are using.

If water should happen to splash on the instrument or the battery, wipe it off immediately and allow it to dry in a dry location.

Auto focus

The Auto focus may not function under every condition depending on brightness, contrast, and the shape and size of the target. In such a case, use the Power Focus buttons or the manual focus ring.

Atmospheric correction

During surveys for which the survey precision or atmospheric measurement method is defined, measure the atmospheric temperature and pressure separately and enter those values rather than using the Automatic Atmospheric Correction function.

1. Basic Operation

1.1 Removing the Battery

- (1) Rotate the knob above the battery pack counter-clockwise.
- (2) Lift up the battery pack and remove it from the instrument.

1.2 Attaching the Battery

- (1) Place the channel on the bottom of the battery pack, onto the protrusion of the instrument and push the battery pack down into place.
- (2) Turn the knob clockwise.

1.3 Turning the Power On and Off

To set power on :  → Electronic vial screen

To shut down : 

NOTE: The power is automatically turned off after 10 minutes of inactivity. (Factory default setting)

1.4 Centering and Leveling (Laser plummet and Electronic vial)

To activate electronic vial :  or 

To activate Laser plummet :   (for the first time after power on)

or 

To deactivate :  or 

NOTE: The laser plummet and the electronic vial are always activated at the same time. When the power is switched on, however, only electronic vial is activated (Factory default setting). To change the power-on activation of laser plummet, refer to “2-3 Instrument setting items”.

1.5 Target Sighting (Focusing)

1.5.1 Auto-Focus

Aim using the telescope collimator, and press 

NOTE: Place the target near the reticle center. The AF sensor is located around the horizontal line of the reticle.

1.5.2 Power focus

If the AF failed or if you need to adjust the focus, use the Power focus knob. 

To focus on a closer object : Rotate Power Focus knob clockwise

To focus on a farther object : Rotate Power Focus knob counterclockwise

NOTE: Focus speed can be controlled by the rotation angle of the knob:

Low speed: when rotated by approx. 5 degrees

Middle speed: when rotated fully by approx. 10 degrees

High speed: after one second of time has passed in the middle speed position

1.5.3 Manual focus

Rotate the focus ring manually : 

1.5.4 Continuous AF mode

To activate the continuous AF:  ... for 2 seconds

NOTE: Track the target by keeping the target close to the center of the reticle as much as possible.

To quit:  or rotate the Power focus knob : 

NOTE: In case the focus does not change for one minute, the continuous AF mode will also terminate automatically.

1.6 Angle Measurement

1.6.1 Horizontal Angle

Set the screen MODE A :  ESC  [or ] → MODE A screen

Control keys for measuring horizontal angle:

To set the angle to 0 :  F3 →  F3

To hold the angle :  F5 →  F3 →  F3

To release HOLD :  F3

To input an angle :  F5 →  F2 →  F4 →  F5







→ input value by using  F1 ,  F2 , 0 - 9 , . → 



To read clockwise angle :  F5 →  F2 →  F4 x2 →  F5

1.6.2 Vertical angle

To display vertical angle :  F4

To change permanently the combination of values displayed in MODE A;

 +  →  F2 x2 →  F5 →  F4 x3 →  F5 →

→ Select by  F3 or  F4 →  x3

To read the slope % :  F5 →  F2 →  F5

1.7 Distance Measurement

Set the screen MODE A:  →  [or ] → MODE A screen

1.7.1 Select your target

Select target type (measurement mode):

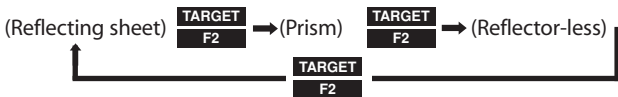



NOTE: The selected target is maintained until next time you change.

1.7.2 Distance measurement

For a single shot measurement:  When "Long Range Mode" is displayed

NOTE: "Long Range Mode" is displayed only when measuring with higher laser power (in reflectorless measurement with the instrument setting "REF.LESS RANGE" set as "LONG" and "Warning Message" set as "ON")

For tracking measurement:  → 

NOTE: The number of shots can be defined. The default is "one time". The measuring modes activated by the above operations can be also changed.

1.7.3 Changing Target constants

The default constants are:





Reflecting sheet : 0 mm
Prism : -30 mm
Reflector-less : always 0 mm





Before changing the constants, set Target Constant in the Initial Setting to

"INPUT" mode:  +  →  →  x2 →  x2 →  x3

To change Prism constant:  →  →  →

→ input value by using  ,  ,  ,  ,  →  x2

To change Sheet constant:  →  →  →  →

→ input value by using  ,  ,  ,  →  x2

1.7.4 Input Temperature and Atmospheric pressure

The default atmospheric correction mode is "Automatic".

Before manual input, change the default mode to "ATM INPUT":

 +  →  x2 →  →  →  x2

To Input temperature :  →  →  x2 →  →

→ input value by using  ,  ,  ,  →  x2



To Input atmospheric pressure:

 →  →  x3 →  →

→ input value by using  ,  ,  ,  →  x2

1.7.5 Laser pointer

To activate Laser pointer :  → 

To quit Laser pointer :  → 

NOTE: The laser pointer is kept activated until it is deactivated by the above procedure.

1.7.6 Adjusting Laser Plummet brightness

 →  →  or  → 

1.7.7 Adjusting LCD contrast

 +  →  or  → 

1.7.8 Adjusting Illumination brightness

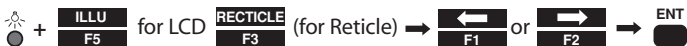

2. Changing Instrument settings

You can change the instrument settings by “HELP” menu or by inputting “007” code.

1 Help menu

While the screen is in MODE A or MODE B,



NOTE: Some items have sub-menus where the selecting procedure by using F1 - F4 is again repeated.

2 “007” code

While the screen is in MODE A or MODE B,

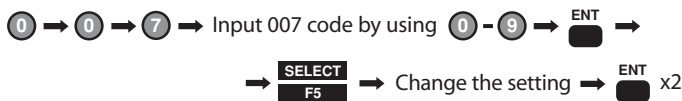

NOTE: Some items have sub-menus where the selecting procedure by using F1 - F4 is again repeated.

3 Instrument setting items

See chart on page 14

007 code	HELP menu list	Default	Other options
401	TARGET CONST	PRISM CONST -30mm SHEET CONST	0mm, INPUT INPUT
402	ATM CORR	AUTO	ATM INPUT, ppm INPUT, NIL
501	MEAS. MIN DISP	COARSE	FINE
502	SHOT COUNT	SHOT CONT SHOT INPUT	3 times, 5 times, INPUT (input)
503	CRV/REF CORR	01 times 0.14	0.2, NIL
504	MIN UNIT ANG.	FINE	COARSE
505	V.ANG. STYLE	Z 0	H 0, COMPASS
508	DIST.BUZ	ON	OFF
509	QUAD BUZ	OFF	ON
510	AUTO OFF	10 MIN	20 MIN, 30 MIN, NIL
511	EDM OFF	3 MIN	5 MIN, 10 MIN, NIL
512	ILLU.OFF	3 MIN	5 MIN, 10 MIN, NIL
514	MEAS.SIGNAL	MARK	VALUE
515	PRIORITY SELECT	PRIM.MEAS KEY SEC.MEAS KEY AUTO MEAS. PRIORITY DISP	MEAS CONT, TRACK SHOT, TRACK CONT TRACK SHOT, MEAS CONT, MEAS SHOT MEAS., TRACK HA/VA/SD, HA/VA/HD/SD/MD
516	COORD.AXIS (for PSF software only)	XYZ	XYZ, NEZ, ENZ
517	COMP AXIS	3 Axis (2/3" model) or 2 Axis	2 Axis (2/3" model), 1 Axis, NIL
520	LD PLUM.&E.VIAL	LD PLUM. TILT DISP.	ON (when Power On) OFF ON (automatically ON)
521	REFLESS RANGE	TILT DISP.UNIT RANGE	FINE LONG
701	ATM UNIT	MESSAGE SETUP	OFF PERMANENT
702	DIST.UNIT	TEMP.UNIT PRESS UNIT	Fahrenheit mmHg, inchHg
703	ANG.UNIT	m DEG	ft, ft+inch DEC, GRD, MIL
801	SET UP COM.	BAUD RATE DATA LENGTH PARITY BITS STOP BITS	2400, 4800, 9600 7 EVEN, ODD
		SIGNAL CONTROL XON/XOFF	2 OFF OFF
		THROUGH COMMAND	a, b, c, d, e, f



3. Basic Field Checking Procedures

Checks and Adjustments should be performed before and during measurement.

3.1 Electronic Vial

To display vials :  or  (from measurement screen)

Check if the bubble stays at the center of each vial, when rotating the instrument by 180°.

To adjust the vials:  +  operate according to the instruction on the screen

NOTE: Press these two keys for 1 second longer, then release  key first.



3.2 Laser Plummet

To activate the laser plummet:  →  →  (for the first time after Power on) or  → (from measurement screen)

Check if the laser spot on the ground stays at the same position when rotating the instrument around the vertical axis.

To adjust the laser plummet: Contact your local dealer

3.3 Laser Pointer

To activate the laser pointer:  → 

or  (from measurement screen) → 

Check if the projected laser spot points at the same position that is aimed by the center of the cross-hair line of the telescope.

To adjust the laser pointer: Consult your local dealer.

3.4 Error Messages

Message	Meaning	What to do
Out of tilt range	Displayed when the instrument is tilted beyond the vertical compensation range ($\pm 3'$) in case 1 axis or 2 axis auto-matic compensation is selected. This message may be temporarily displayed if the instrument is turned too fast.	Re-level the instrument. Repair is needed if the message is displayed when it is properly leveled.
Excess data	The input data exceeds the allowable range.	Press the [ESC] key and enter the correct data.
Mismatched Target	<ul style="list-style-type: none">•The distance is measured by Prism in Reflector sheet mode, and the distance is over 1000m.•The distance is measured by Prism or Reflector sheet in Reflectorless mode, and the distance is over than 200m.	Select the correct target mode.
Target is too close.	<ul style="list-style-type: none">•The measurement distance is less than 1.5m in Reflector sheet mode.•The measurement distance is less than 1.5m in Prism mode.	Select a longer point, or use a tape measure.
Unsuitable Condition	<ul style="list-style-type: none">•Under too strong sun light.•Unstable light value owing to shimmer or obstacles.•Reflector sheet, Target and Prism do not face the instrument.•Reflector sheet, Target and Prism are not correctly sighted.•Measurement range is over in Reflectorless mode.•Sufficient signal does not return by sighting sharp edge etc. at Reflectorless mode.	Change the object that has much better reflectivity, or use a reflecting sheet, or wait until the sun activity has weakened.
ERROR!! EDM ERROR 04 -05, 34-39, 50-53	Distance measurement system problem	Turn the power off, and then turn on again.
ERROR!! ETH ERROR 70-76	Angle measurement system problem	Repair is needed when the message appears consistently.
ERROR!! MEMORY ERROR 19	Memory problem	
ERROR S DATA of EDM	Problem of the internal EDM parameters	
ERROR P DATA of EDM		
ERROR ETH DATA	Problem of the internal ETH parameters	

4. Specifications

Reflectorless items are applicable to "N" models only.

	R-322 (N)	R-323 (N)	R-325 (N)	R-335 (N)	R-315 (N)	R-326
Telescope						
Magnification	30 x					
Resolving power	3"					
Field of view	2.6% (1° 30')					
Minimum focus	1.0m					
Auto-Focus	Auto-focus / Power Focus / Manual					Manual
Distance measurement						
Laser Class	Visible Laser: Class II (2) / Class IIIa (3R) -Long range mode in Reflectorless					
Measurement range	(Good condition)					
Reflectorless	1.5m -Normal range mode: 70m (90m), / Long range mode 150m(180m) /					
Reflector sheet	1.5m - 600m (800m)					
Mini prism	1.5m - 1100m (1600m)					
1P	1.5m - 3400m (4500m)	1.5m - 3000m (4000m)		1.5m-2000m ^(2800m)		
3P	200m - 4500m (5600m)	200m - 4000m (5000m)		200m -2800m ^(3500m)		
Accuracy						
Prism	±(2+2ppm	±(3+2ppm	±(5 + 3ppm x D)mm			
Reflector Sheet	x D)mm	x D)mm				
Reflectorless	±(5 + 2ppm x D)mm		±(5 + 3ppm x D)mm			
At Auto-Atm. Correction	Prism, Ref.sheet: ±(3 +10ppm x D)mm / Reflectorless: ±(5 +10ppm x D)mm					
Measuring time (minimum count)						
Fine	2.5sec. (0.1mm)					
Normal	1.5sec. (1 mm)					
Track	0.4 sec. (1 cm)					
Angle measurement						
Measuring method	Absolute rotary encoder					
Detection	2 sides					
Minimum count	1" (2cc) / 5" (10cc) selectable					
Accuracy(DIN18723)	2"	3"	5"			6"
Compensator	Triple axis		Dual axis			
Tangent screw	2 speed		1 speed			
Sensitivity of vials						
Plate level (electronic)	30"/1div.					40"/1div.
Circular level	8'/2mm					
Plummet	Visible Laser, ±0.8 mm (instrument height 1.5m)					
Base	Detachable		Shifting	Fixed	Detachable	
Water resistant	IPx6 (instrument only)					
Ambient temperature	-20°C ~ +50°C / -4°F ~122°F (Working range)					
Tripod thread	5/8" x 11		35mm x 2	5/8" x 11		
Dimensions/Weight						
Instrument	172(W) x 343(H) x 440(L) mm					
Weight (incl. Battery)	5.7 kg		5.5 kg		5.7 kg	
Carrying case	268(W) x 442(H) x 465(L) mm/3.9kg					
Battery pack BP02						
Power source	Ni-MH (Rechargeable)(4300mAh) , DC6V					
Operation time	Continuous Approx. 5 hrs (ETH+EDM), 12 hrs (ETH) with Approx. 2.2 hrs of charging time					
Weight	Approx. 380g					
Charger BC03 and AC Adapter AC01						
Input voltage	DC16V , 100~240V					
Output voltage	DC7.5V/ 9V , DC16V					
Weight	280g					
Internal Memory						
Coordinates data	7500 points (Measured and input coordinate data)					

- NOTE:**
- Reflector sheet: By PENTAX genuine Reflector sheet (5cm x 5cm)
 - Normal conditions: 20km visibility with slight shimmer
 - (Good conditions): 40km visibility, overcast, no heat no shimmer and moderate wind
 - Reflectorless The measurement range and accuracy are determined by the white side of the Kodak Gray Card.
The measurement range at TRACK mode is over 5m.
The measurement range may vary by measurement conditions.
 - The operating time becomes shorter under the low temperature, due to the temperature dependence of the battery performance.

NOTICE TO THE USER OF THIS PRODUCT

To assure compliance with the Safety standard 21 CFR, Chapter 1. Subchapter J. The U.S. bureau of Radiological Health requires the following information to be provided to user.:

It can be dangerous to look into the beam with optical equipment such as binoculars and telescopes.

1. Specifications of Laser Radiation

- A) The EDM module of the R-300 produces a visible light beam, which is emitted from the telescope objective lens and the center hole of the instrument base plate. The R-300 is designed and built to have a laser diode radiating at 620-690 nm.

- B) Radiant power
The R-300 is designed and built to radiate a maximum average radiant power of 4.75mW (0.95mW for the model without "N") from the telescope, and 0.95mW from the center hole of the base plate. The user may be subject to this radiation as a beam while operation until such time that the instrument is turned off.





2. The following labels are affixed to and must remain attached to this laser product.

- A) The following Certification label is located near the Plate level.: "This laser product is complied with the provisions of 21 CFR 1040.10 and 1040.11. For a Class II laser product."
Or for R-300 N models:
"This laser product is complied with the provisions of 21 CFR 1040.10 and 1040.11. For a Class IIIa laser product."

- B) Caution label is located near the exit aperture :
"AVOID EXPOSURE Laser radiation is emitted from this aperture."

- C) Warning logotype is located on the surface of the telescope:
"CAUTION LASER RADIATION DO NOT STARE INTO BEAM"
- Or for R-300 N models:
"DANGER LASER RADIATION AVOID DIRECT EYE EXPOSURE"
- D) Warning label is Located near the exit aperture.

3. Caution to maintain the safety in compliance with the standard

- A) To maintain the safety standard, refrain from any operation, maintenance, or adjustment other than described in this instruction manual.
- B) Operation, maintenance or adjustment other than those specified in this instruction manual may result in hazardous radiation exposure.
- C) Maintenance and repair not covered in this manual must be done by an authorized Pentax dealer.
- D) The Laser beam emission by the Distance measurement can be terminated by pressing  key.
- E) Pressing  →  keys can terminate the laser beam emission by the laser pointer.
- F) The Laser beam emission by the Laser plummet can be terminated by pressing  key.

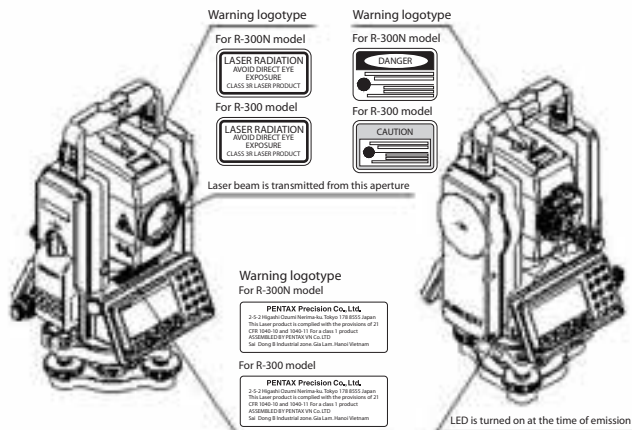
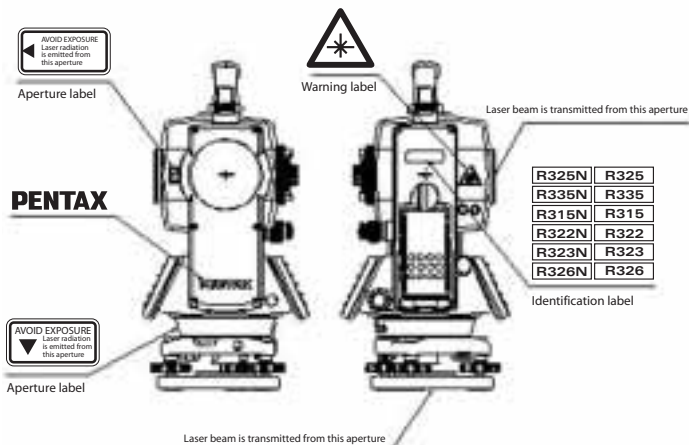

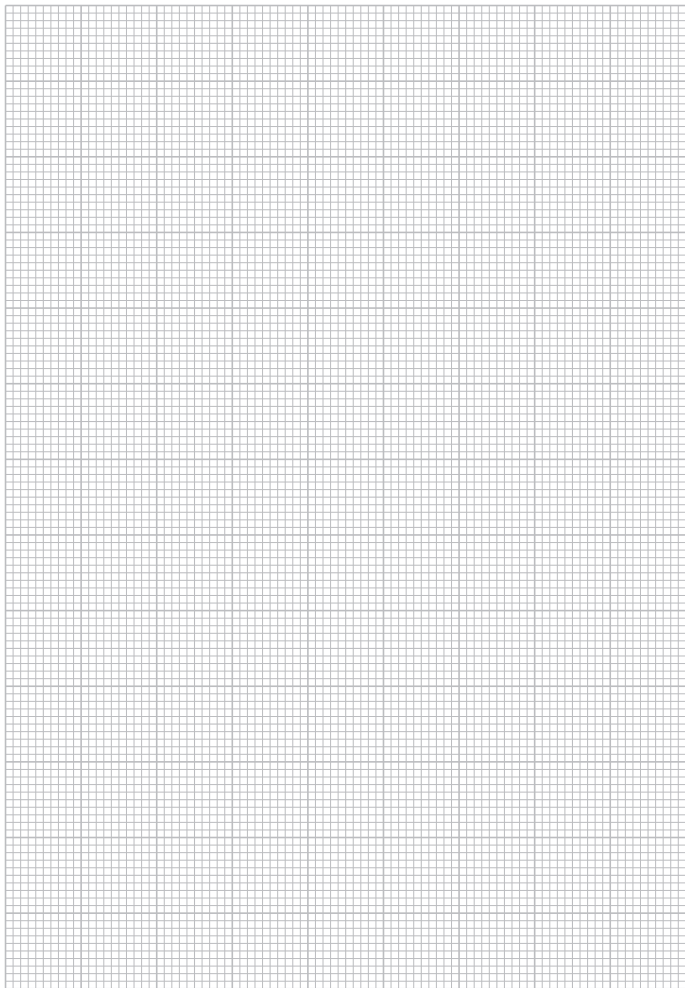



The CE marking assures that this product complies with the requirements of the EC directive for safety.

Danger

LASER RADIATION - DO NOT
STARE INTO BEAM
OR VIEW DIRECTLY WITH
OPTICAL INSTRUMENT.



Peak Power 4,95 mW Wavelength 620 - 690nm

CLASS IIIA LASER PRODUCT

Laserclass III, conform FDA 21 CFR

Ch. 1 § 1040

CAUTION

LASER RADIATION - DO NOT
STARE INTO THE BEAM



620-690 nm/ max. 0,95 mW

CLASSE II LASER PRODUCT

LaserclassII, conform FDA 21 CFR

Ch. 1 § 1040

PENTAX Precision Co., Ltd.

2-5-2 Higashi-Oizumi

Nerima-ku, Tokio 178-8555, Japan

Tel.: +81-3-5905-1222

Fax: +81-3-5905-1225

E-mail: international@ppc.pentax.co.jp

Web-Site: <http://www.pentax.co.jp/ppc/>

PENTAX®



certified



The CE marking assures that this product complies with the requirements of the EC directive for safety.



Member symbol of the Japan Surveying Instruments Manufacturers' Association representing the high quality surveying products.